

# Mathematical modelling and simulation of a rocket's take-off trajectory

Maria Alejandra Botero Botero  
Ingeniería Mecánica  
Universidad EAFIT  
Medellín  
mboter45@eafit.edu.co

Alejandro Murillo Gonzalez  
Ingeniería Matemática  
Universidad EAFIT  
Medellín  
amurillo@eafit.edu.co

Juan Pablo Vidal Correa  
Ingeniería Matemática  
Universidad EAFIT  
Medellín  
jpvidalc@eafit.edu.co

**Abstract**—A rocket is a vehicle that launches into space or describes a suborbital flight. It's subjected to the forces of weight, thrust, and the aerodynamic forces, lift and drag. The relative magnitude and direction of the forces determines the flight trajectory of the rocket. The objectives of this paper are to model the rocket's take-off trajectory and understand the tradeoff when using the main engine in conjunction with the lateral thrusters. Also, to obtain a linear model that represents the altitude obtained by the rocket in the ascending phase and to examine system behavior through stability and sensitivity analysis.

Rocket's trajectory is obtained in four situations depends on the engine or thrusters that are in operation. Linearization methods were used to replace the model by a simpler function due to the possibility of use tools for studying linear systems to analyze the behavior of a nonlinear function near a given point and because a linear model is required for certain types of analysis such as stability analysis. Finally, sensitivity analysis of the parameters of the model is used to study how the uncertainty in the output of a mathematical model can be apportioned to different sources of uncertainty in its inputs.

**Index Terms**—Rocket, flight dynamics, Simulink, thrust, model, trajectory.

**Resumen**—Un cohete es un vehículo que se lanza al espacio o describe un vuelo suborbital. Está sujeto a las fuerzas gravitacionales o peso, empuje, y las fuerzas aerodinámicas, sustentación y arrastre. La magnitud relativa y la dirección de las fuerzas determina la trayectoria de vuelo del cohete durante la fase de despegue. Los objetivos de este documento son modelar la trayectoria de un cohete en la fase de despegue y comprender la compensación cuando se usa el motor principal junto con los propulsores laterales. Además, obtener un modelo lineal que represente la altitud obtenida por el cohete en la fase ascendente y examinar el comportamiento del sistema a través del análisis de estabilidad y sensibilidad.

La trayectoria del cohete fue obtenida para cuatro situaciones dependiendo del motor o propulsores que están en operación. Se utilizaron métodos de linealización para reemplazar el modelo por una función más simple que permite estimar la altitud obtenida por el cohete en la fase ascendente, dada la posibilidad de usar herramientas para estudiar sistemas lineales para analizar el comportamiento de una función no lineal cerca de un punto dado y porque un modelo lineal es requerido para ciertos tipos de análisis, como el análisis de estabilidad. Finalmente, se utiliza el análisis de sensibilidad de los parámetros del modelo para estudiar cómo la incertidumbre en la salida de un modelo matemático se puede distribuir a diferentes fuentes de incertidumbre en sus entradas.

**Palabras clave**—Cohete, dinámica de vuelo, Simulink, empuje, modelo, trayectoria

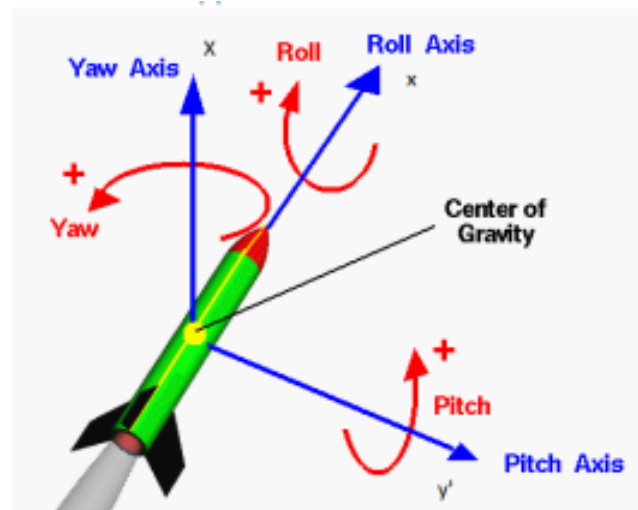

Figure 1: Rocket system (credit: NASA)

## I. INTRODUCTION

Rocket flight is described, mainly, by using Newton's second law. The first phase of a rocket flight is the take-off. At launch, the thrust of the rocket engine is greater than the weight of the rocket and the net force accelerates the rocket away from the pad. During launch, the velocity is too small to provide sufficient stability, so a launch rail is used. Leaving the pad, the rocket begins a powered ascent. Thrust is still greater than weight, and the aerodynamic forces of lift and drag now act on the rocket. When the rocket runs out of fuel, it enters a coasting flight. The vehicle slows down under the action of the weight and drag since there is no longer any thrust present. While the rocket has been coasting, a delay "charge" has been slowly burning in the rocket engine. It produces no thrust, but may produce a small streamer of smoke which makes the rocket more easily visible from the ground. At the end of the delay charge, an ejection charge is ignited which pressurizes the body tube, blows the nose cap off, and deploys the parachute. The rocket then begins a slow descent under parachute to a recovery. The forces at work here are the weight of the vehicle and the drag of the parachute. After recovering the rocket, you can replace the engine and fly again.

In this paper is showed a mathematical model of a rocket take-off trajectory through six degrees of freedom equations of motion. This model is developed in MATLAB and Simulink simulation and can be easily adjusted for any type of rocket. Four situations are considered depends on the engine or thrusters that are in operation. Also, linearization methods, and stability and sensitivity analysis are used to examine system behavior.

## II. MATERIALS AND METHODS

### A. System description

It's modelled a policy for rocket Vertical Take-off and Landing (VTOL). Specifically, it is focus on the first phase of a rocket's flight, the take-off. The policy is intended to accommodate a variety of scenarios, that means, that the rocket will be able to launch from different initial states. Those states vary according to the planet (or moon) surface and environment. Some of this initial conditions are randomized, since it can not have deterministic data for them. Furthermore, since it's followed the work of [1], the model does not take into account: planetary rotation, gravity differentials, drag and mass losses. In addition, it's assumed that the rocket is a cylinder.

The model has 6 degrees of freedom (6 DOF), meaning that the motion will take into account the rocket's position with respect to the X, Y and Z axis; also, it will consider the yaw, pitch and roll. Figure 1 represents the 6 DOF [2].

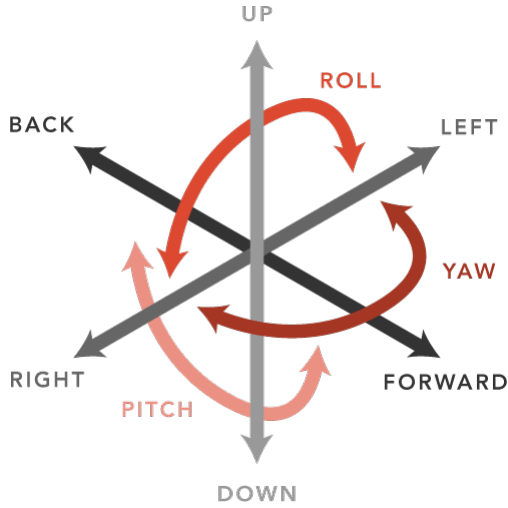

Figure 2: Six DOF

### B. Mathematical model description

The altitude and lateral position of rocket's center of mass are defined as (X, Y, Z) and the rotational position with Euler Angles ( $\psi$ ,  $\theta$ ,  $\phi$ ), which are respectively yaw, pitch and roll.

The model is neglecting planetary rotation, gravity differentials, drag and mass losses. Also, the rocket is being approximated as a cylinder and it is considered as a rigid body.

The x-axis is the altitude, and therefore the gravitational force is in the  $-x$  direction. [2]

Regarding force capability, the rocket engine is an axial Merlin 1D, theoretically capable of 147,000lbs of thrust. It's enforced that this main rocket is always firing. There are effectively 4 cold gas thrusters on rocket for lateral stability; one in each quadrant, capable of firing in one direction.

Angular momentum, linear momentum, and energy are all quantities that are NOT conserved.

The state is therefore:

$$\bar{x} = [X \ Y \ Z \ \dot{X} \ \dot{Y} \ \dot{Z} \ \psi \ \theta \ \phi \ \dot{\psi} \ \dot{\theta} \ \dot{\phi}]^T \quad (1)$$

The resulting equations of motion are:

$$\ddot{x} = \frac{1}{m} (F_x c\psi c\theta + F_y (c\psi s\theta s\phi - s\psi c\phi) + F_z (s\psi s\phi + c\psi s\theta c\phi)) - g \quad (2a)$$

$$\ddot{y} = \frac{1}{m} (F_x s\psi c\theta + F_y (c\psi c\theta + s\psi s\theta s\phi) + F_z (s\psi s\theta c\phi - c\psi s\phi)) \quad (2b)$$

$$\ddot{z} = \frac{1}{m} (-F_x s\theta + F_y c\theta s\phi + F_z c\theta c\phi) \quad (2c)$$

$$\ddot{\phi} = \frac{M_x}{I_a} + \dot{\psi}\dot{\theta}c\theta + \frac{s\theta}{I_t c\theta} (M_z c\phi + M_y s\phi + I_a (\dot{\phi}\dot{\theta} - \dot{\psi}\dot{\theta}s\theta) + 2I_t \dot{\psi}\dot{\theta}s\theta) \quad (2d)$$

$$\ddot{\theta} = \frac{1}{I_t} (0.5(I_a - I_t)\dot{\psi}^2 s 2\theta - I_a \dot{\phi} \dot{\psi} c \theta + M_y c \phi - M_z s \phi) \quad (2e)$$

$$\ddot{\psi} = \frac{1}{I_t c \theta} (M_z c \phi + M_y s \phi + I_a (\dot{\phi} \dot{\theta} - \dot{\psi} \dot{\theta} s \theta) + 2I_t \dot{\psi} \dot{\theta} s \theta) \quad (2f)$$

Where s represents the sine function and c the cosine function.

### C. Block diagram

Figure 5 shows the block diagram for the system and model described in section II. It consists of blocks that represent the different parts of the system and signal lines that define the relationship between the blocks.

Block diagram provides a high-level graphical representation of

real-world system and allows analyzing dynamic system behavior in time domain.

The equations of motion for position and orientation are written in MATLAB scripts due to its complexity.

Linear and rotational accelerations in all 6 degrees of freedom are integrated twice to produce linear and angular displacements.

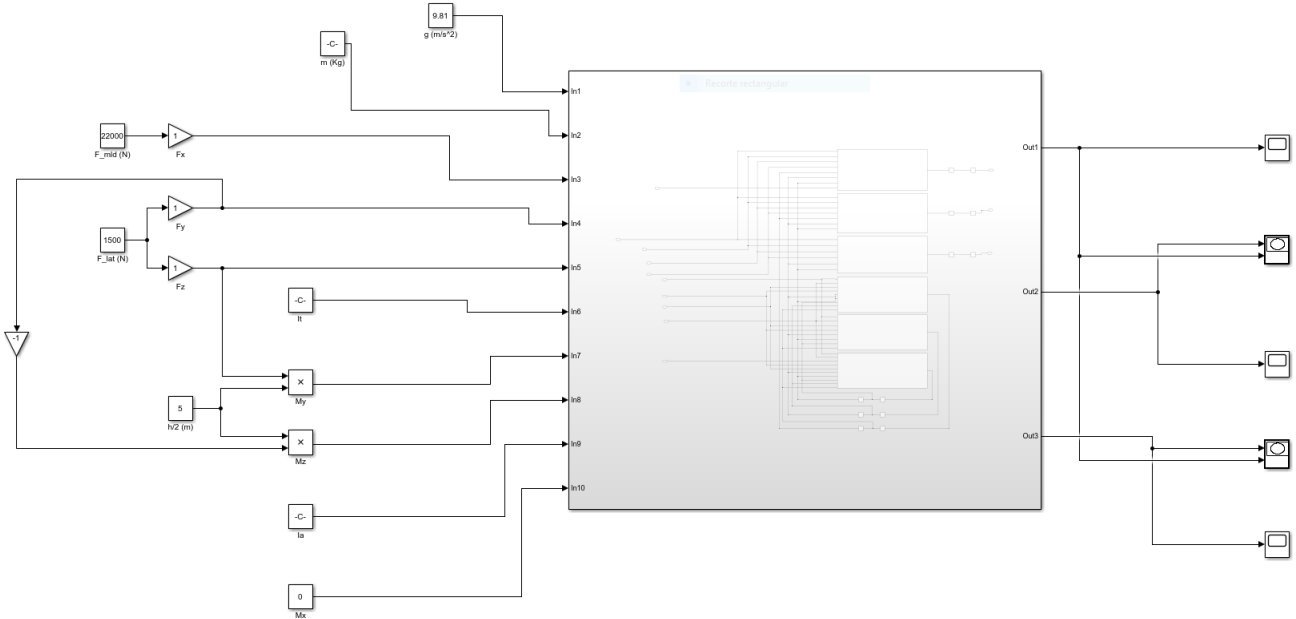

Figure 3: Block diagram

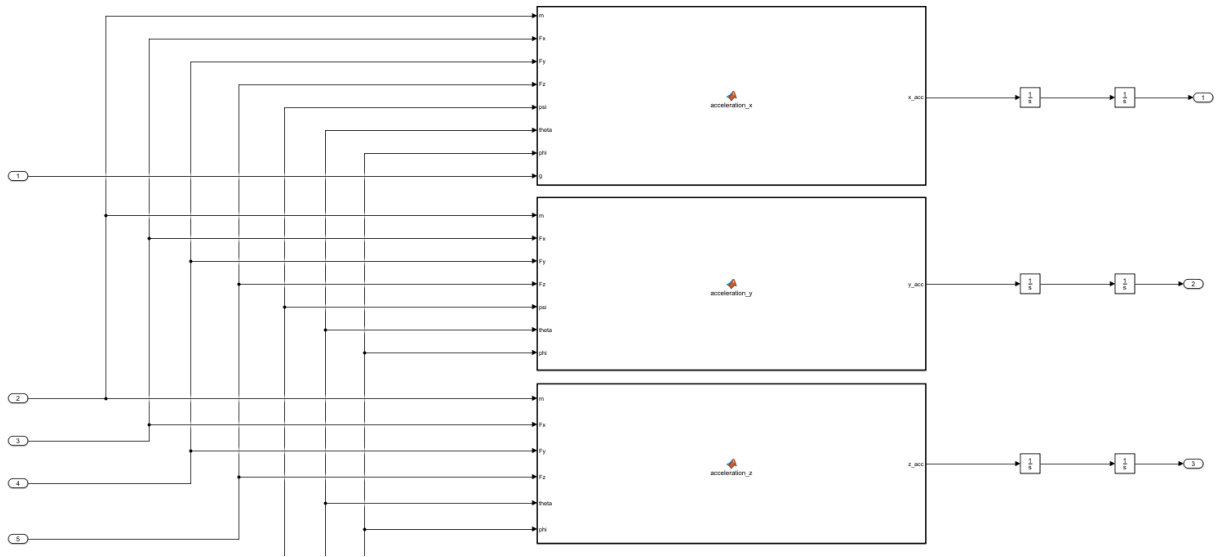

Figure 4: Position

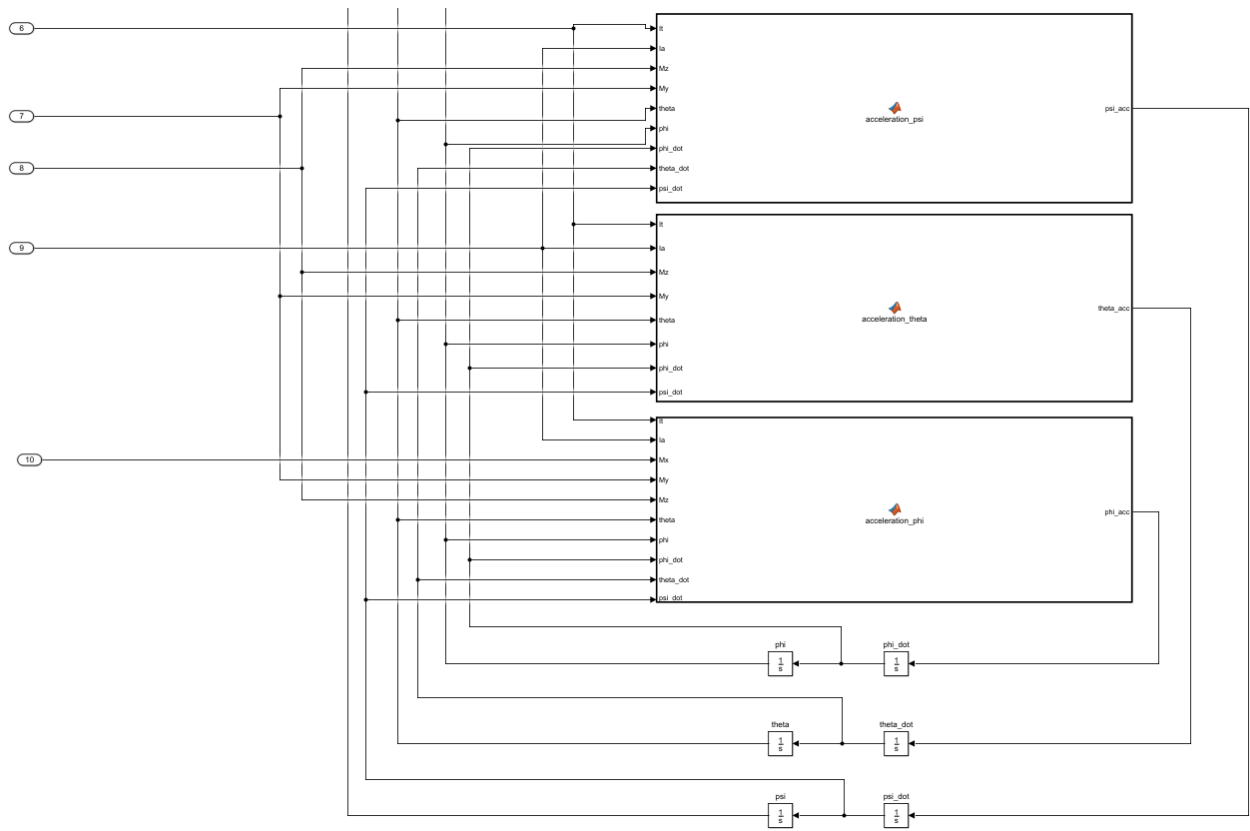

Figure 5: Orientation

#### D. Simulation methods

Four situations are considered depends on the engine or thrusters that are in operation. This table shows the parameters at each simulation. The MID engine is the central engine that drives the rocket towards the X direction (above), in the equations in represented by  $F_x$  and the thrusters are engines that expel lateral cold gas to stabilize the trajectory of the rocket, these have a lower force (as seen in the previous section) than the MID engine, and only operate on the Y axis (Thruster 1) and Z axis (Thruster 2).

Parameters	1	2	3	4
MID engine	X	X	X	X
Thruster 1	X		X	
Thruster 2	X			X

Table I: Situations

The parameters of the simulation were the following:

Start time	0
Stop time	15
Type	Fixed step
Fixed-step size	0.1
Solver	ode1(Euler)

Table II: Simulation parameters

The research in which the simulation was based use Euler's method to generate the derivatives of the previous equations. The simulation time was short because the specified parameters (based on a Falcon 9 rocket) didn't allow a very long flight time, which generated irregularities in the results. In the research, flight times do not exceed 11 seconds.

#### E. Initial conditions and parameters

$g$	$9.81m/s^2$
$m$	$2513.74kg$
$F_x$	$22000N$
$F_y$	$1500N$
$F_z$	$1500N$
$I_t$	$171000kgm^2$
$h$	$10m$
$I_a$	$451000.61kgm^2$
$M_x$	0

Table III: Model parameters

Initial conditions for all integrators are zero.

#### F. Linearization

1) *Critical points*: Through the function `vpsolve2` was obtained the numerically critical point of the system of equations, as shown in Figure 6.

```
>> z.x
ans =
0
>> z.y
ans =
0
>> z.z
ans =
0
```

Figure 6: Critical point

2) *Linearization curve*: The linearization curve is not required because there is only one operation point that has physical sense.

3) *Equilibrium points*: The equilibrium point is supposed to be:

$$\bar{x} = [X \ Y \ Z \ \dot{X} \ \dot{Y} \ \dot{Z} \ \psi \ \theta \ \phi \ \dot{\psi} \ \dot{\theta} \ \dot{\phi}]^T$$

$$\bar{x} = [X \ 0 \ 0 \ 0 \ 0 \ 0 \ 0 \ 0 \ 0 \ 0 \ 0 \ 0]^T$$

It's required to assume that the equilibrium point is zero everywhere except on the X-axis since it's representing an ascending motion that does not take into account rotations nor displacements on YZ-plane. If that assumption is not made, the model will not have an equilibrium point due to system instability, so linearization couldn't be accomplished.

4) *A, B, C and D matrices*: Through, the `linmod3` function are obtained A, B, C, D matrices at the point of operation.

```
A =
0 0 0 1.0000 0 0 0 0 0 0 0 0
0 0 0 0 1.0000 0 0 0 0 0 0 0
0 0 0 0 0 1.0000 0 0 0 0 0 0
0 0 0 0 0 0 0 0.5967 0 0 0 0
0 0 0 0 0 0 8.7519 0 -0.5967 0 0 0
0 0 0 0 0 0 0 -8.7519 0.5967 0 0 0
0 0 0 0 0 0 0 0 0 0 0 1.0000
0 0 0 0 0 0 0 0 0 0 1.0000 0
0 0 0 0 0 0 0 0 0 1.0000 0 0
0 0 0 0 0 0 0 -0.0439 0 0 0 0
0 0 0 0 0 0 0 0 0.0439 0 0 0
0 0 0 0 0 0 0 0 0.0439 0 0 0
```

Figure 7: Matrix A

B =

1.0e-03 \*

0

0

0

0.3978

0

0

0

0

0

0

0

0

Figure 8: Matrix B

C =

1	0	0	0	0	0	0	0	0	0	0	0
0	1	0	0	0	0	0	0	0	0	0	0
0	0	1	0	0	0	0	0	0	0	0	0

Figure 9: Matrix C

D =

0

0

0

Figure 10: Matriz D

5) *Linear model:* Figure 10 shows the linear model obtained through linearization methods and the block diagram used to make a comparison between the linear and non-linear models.

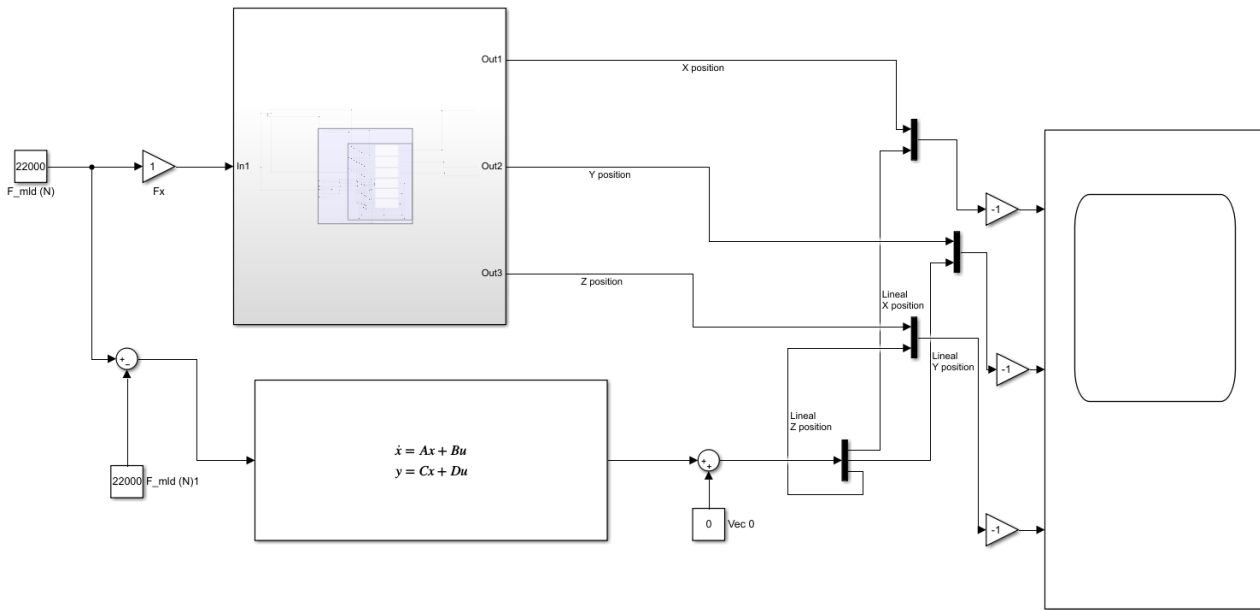

Figure 11: Comparison model

G. Sensitivity analysis

1) *Parameters:* The analysis was done with the following parameters:

- Weight of the rocket:  $m[kg]$
- Height of the rocket:  $h[m]$
- Main engine force:  $F_{mld}[N]$
- Thruster engine force:  $F_{lat}[N]$

To select the parameters to perform the sensitivity analysis was taken into account the most important physical conditions that can be modified when propelling a rocket. These would be the height, weight and engine forces but it is important to take into account

that these parameters must have a defined range around the values they can take, since they must have physical congruence, since the model represents the altitude of a rocket.

The range of values that the parameters can take is expressed through a triangular distribution, since it allows to define the limits in which the parameters must vary, and designates a greater probability to the values that are located in the center.

The above allows to generate the distribution of values of the parameters observed in figure 12.

## A. Situations

### 1) All engines are operating:

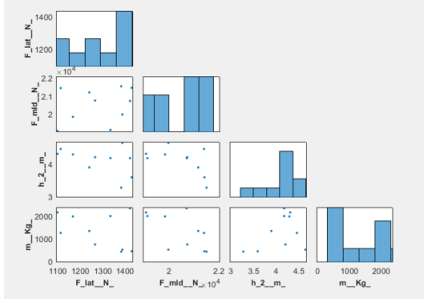

Figure 12: Parameter values

2) *Objective function*: The objective of the model is to maximize the height that the rocket can reach, therefore that it's considered as an objective function of the analysis.

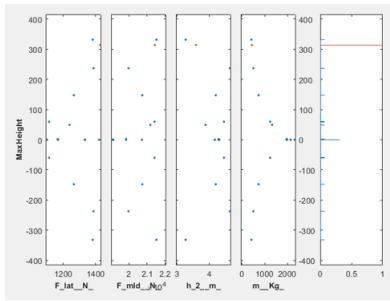
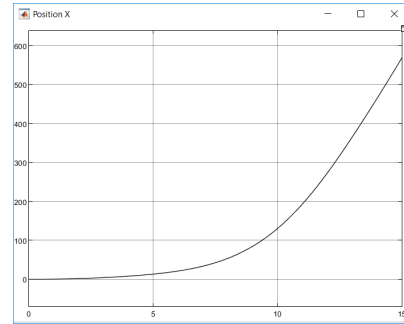

Figure 13: Searching the maximum height value.

## III. RESULTS

The results were taken based on the 4 different situations described above. These situations also allow the verification of the simulation, since they must generate certain trajectories that obey the physical logic of the simulated rocket and its parameters.

It is important to emphasize that the scientific article on which this simulation is based does not generate exact data of its simulation, so it is not possible to compare it, but the trajectories generated by our simulation can be verified based on its behavior.



(a) Position along the X-axis

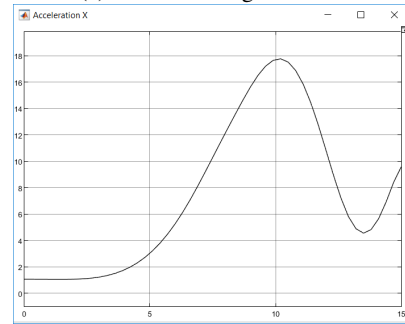

(b) Acceleration in the X-axis

Figure 14: Position and acceleration in the X-axis

These results show a good simulation, since is observed a change of position  $x$  in time, indicating that the MID engine is operating. Also it can be perceived that the simulation does not arrive to land (position  $x$ ), this is because the research on which it was based did not seek to generate a simulation of the trajectory of a rocket, but rather focused on obtaining a combination between operating times of the engines so that the rocket can get the maximum height. Therefore in the simulation of the paper, the rocket never landed, the model recorded the best flight times with different combinations of engines and with reinforcement learning learned from its mistakes (the model itself). It should be noted that the best flight times of the model of the research paper oscillated between 8 and 11 seconds.

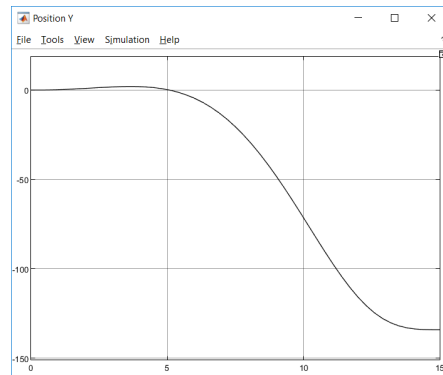
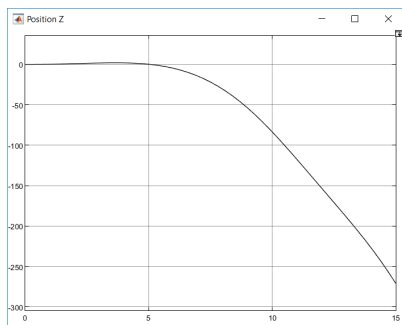

Figure 15: Position along the Y-axis

The results show that the Thruster 1 operated during the flight of the rocket, showing a variation in the position Y (Pitch axis). On the other hand in the graph negative axes are shown, this is due to the reference point and to the pitch movement that the cylindrical body experiences, evidencing the angular acceleration, verifying that the model operates with the 6 DOF.



(a) Position along the Z-axis

The results show that the thruster 2 operated during the flight of the rocket, showing a variation in the position Z (Roll axis). On the other hand in the graph negative axes are shown, this is due to the reference point and to the roll movement that the cylindrical body experiences, evidencing the angular acceleration, verifying that the model operates with the 6 DOF.

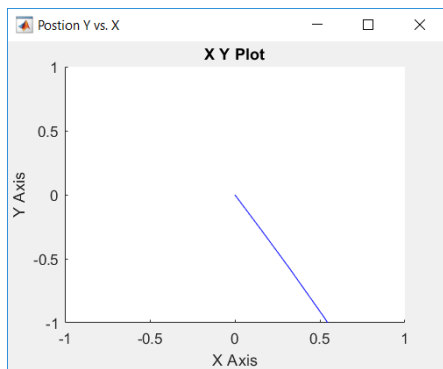

Figure 17: Position Y vs. X

This graph shows that the thruster 1 and the MID operated at the same time.

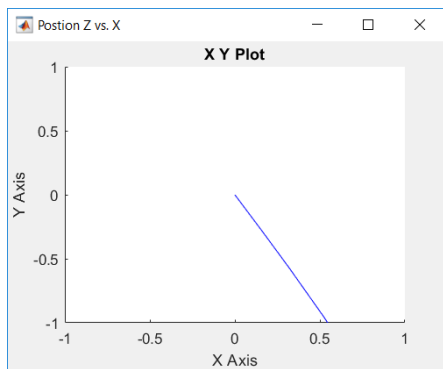
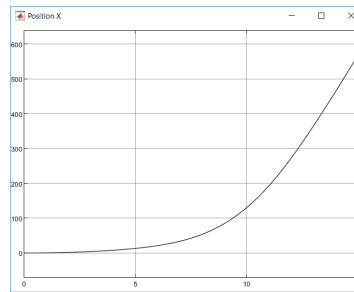

Figure 18: Position Z vs. X

This graph shows that the Thruster 2 and the MID operate at the same time. The Y axis represent the Z axis.

2) **Only MID engine is operating:**



(a) Position along the X-axis

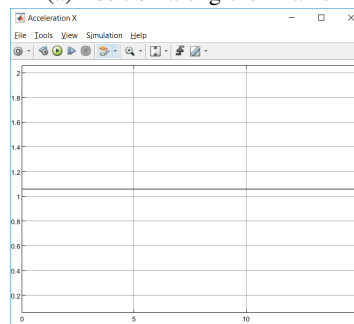

(b) Acceleration in the X-axis

Figure 19: Position and acceleration in the X-axis

The position along X-axis changes, since the MID is active, but the acceleration is constant, since there is only one active motor.

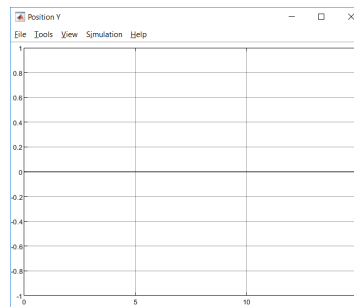

(a) Position along the Y-axis

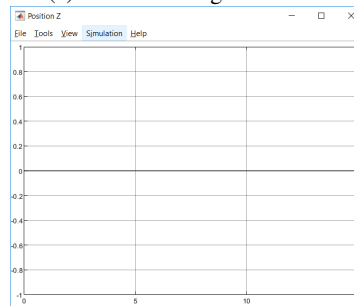

(b) Position along the Z-axis

Figure 20: Position along the Y an Z-axis



As the motor is not operating, there is no change of position on those axis. This extreme behavior allows to verify the simulation.

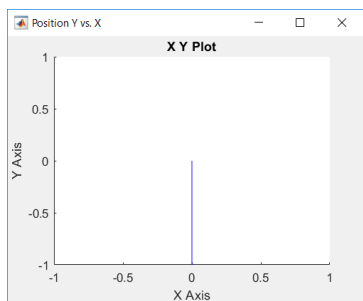

(a) Position Y vs. X

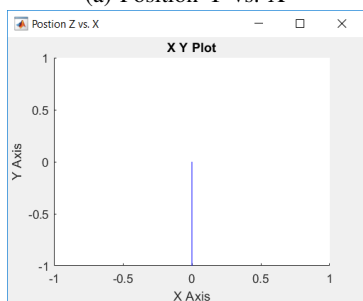

(b) Position Z vs. X

Figure 21: Position Y vs. X and Z vs. X

Those graphs shows that only the MID is operating.

3) **M1D engine and thruster 1 are operating:**

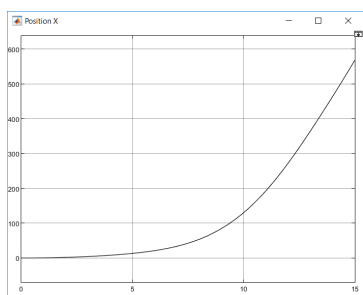

(a) Position along the X-axis

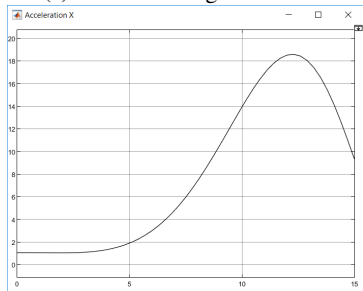

(b) Acceleration in the X-axis

Figure 22: Position and acceleration in the X-axis

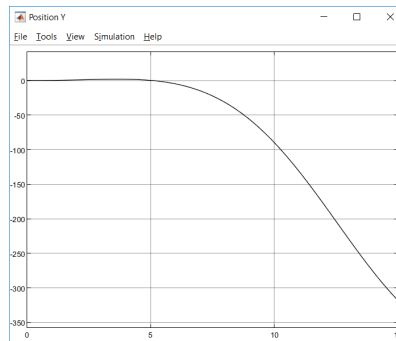

Figure 23: Position along the Y-axis

The results show that the thruster 1 operated during the flight of the rocket, showing a variation in the position Y (Pitch axis).

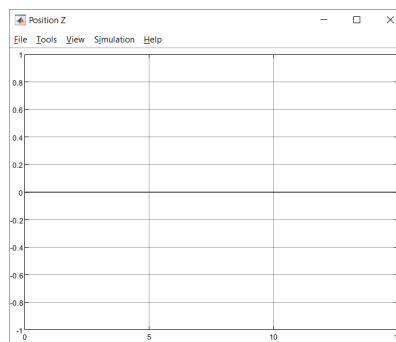

Figure 24: Position along the Z-axis

As the thruster 2 is not operating, there is no change of position on this axis.

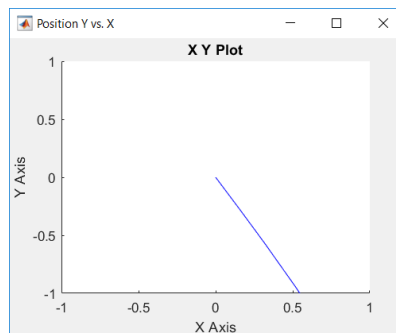

Figure 25: Position Y vs. X

This graph shows that the thruster 1 and the M1D operated at the same time, as is indicated by the situation.

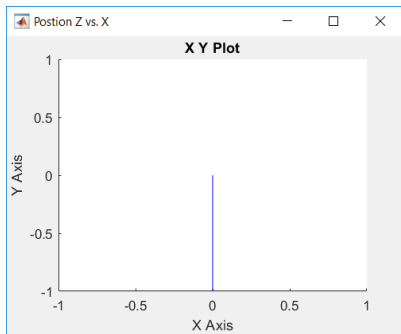
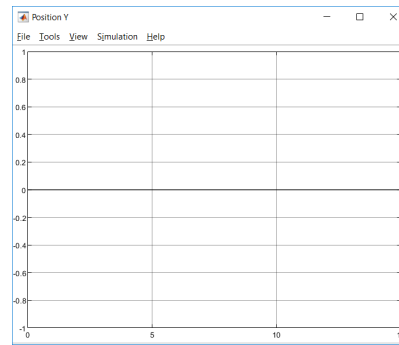

Figure 26: Position Z vs. X

This graph shows that only the MID is operating, because the Thruster 2 is off. (The Y axis represent the Z axis).

4) MID engine and thruster 2 are operating:



(a) Position along the Y-axis

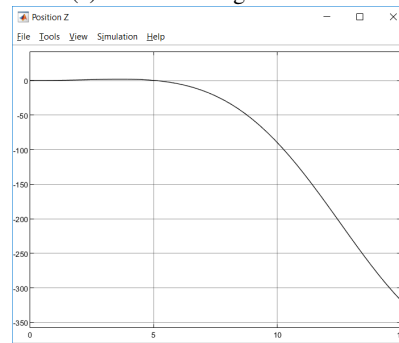

(b) Position along the Z-axis

Figure 28: Position along the Y and Z-axis

The results show that the Thruster 1 operated during the flight of the rocket, showing a variation in the position Z (Roll axis).

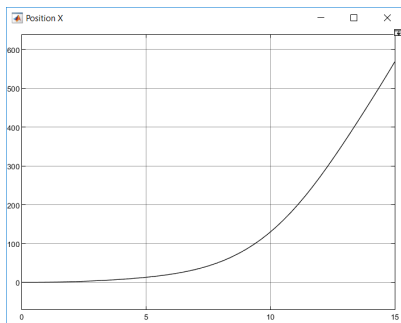

(a) Position along the X-axis

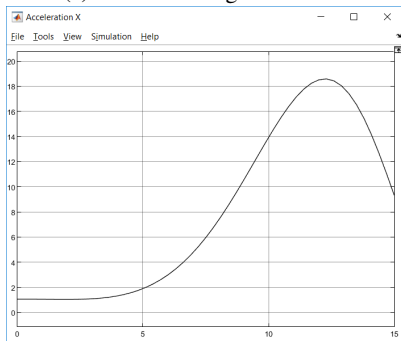

(b) Acceleration in the X-axis

Figure 27: Position and acceleration in the X-axis

The position along X-axis changes, since the MID is active, but the acceleration is constant, since there is only one active motor.

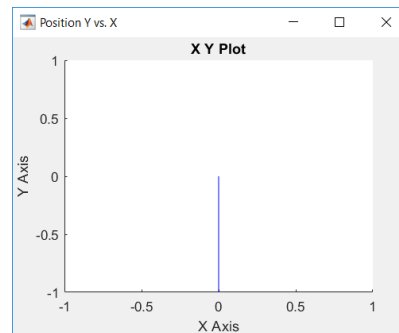

Figure 29: Position Y vs. X

This graph shows that only the MID is operating, because the Thruster 1 is off.

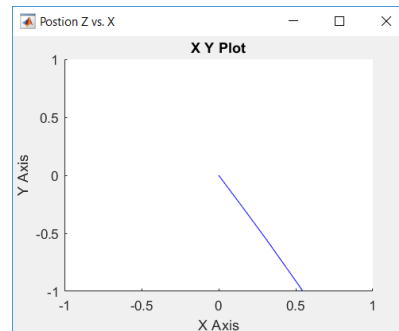

Figure 30: Position Y vs. X

This graph shows that the Thruster 2 and the MID operate at the same time, as is indicated by the parameter. (The Y axis represents the Z axis).

### B. Linearization

The simulation represents just the ascending phase of the rocket, assuming the rotations are zero and due to it, the displacements except altitude are zero. X is not used by the other equations, so it could take any value.

Input value: ( $\Lambda$ )

1)  $\Lambda = \Lambda_0$ : The linear model shows that the trajectory, as the rocket is ascending, follows the curve that describes the rocket's path on the non-linear model, but the adjustment is not perfect; this behavior is not unexpected given the suppositions that were imposed to the linear model.

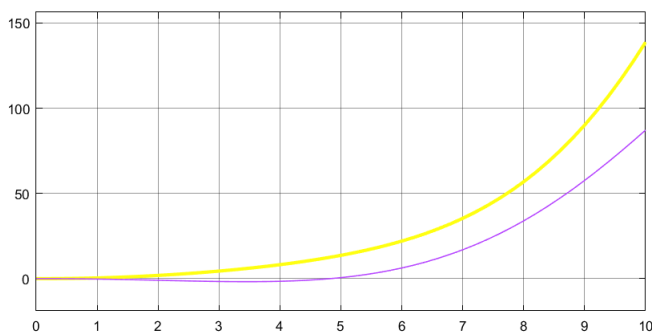

Figure 31: Altitude non-linear model (Yellow) vs. Altitude linear model (Purple)

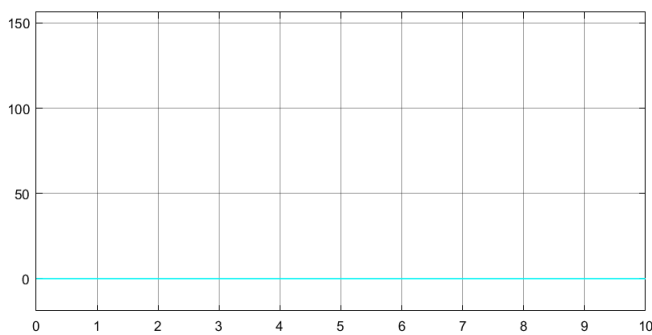

Figure 32: Position on the Y-axis: non-linear model (Blue) vs. linear model (Orange)

The suppositions were imposed to ensure that the rocket keeps ascending while staying on the same coordinates in the YZ-plane and without rotating, then the graphs represent that it stays on path.

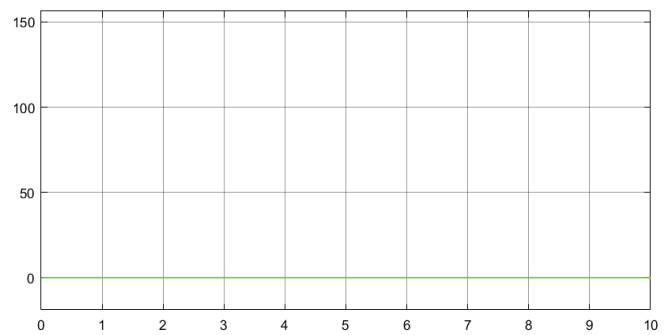

Figure 33: Position on the Z-axis: non-linear model (Blue) vs. linear model (Orange)

As expected, given the suppositions, the trajectories represent that the rocket stays on path. (Similar to the previous Figure/Case).

2)  $\Lambda > \Lambda_0$ : Similar to Figure 31 the linear model shows that the trajectory, as the rocket is ascending, follows the curve that describes the rocket's path on the non-linear model.

The position on the Y-axis and Z-axis is the same as the  $\Lambda = \Lambda_0$  case, since the model is follow a straight path from the X-axis, and thrusters don't fire.

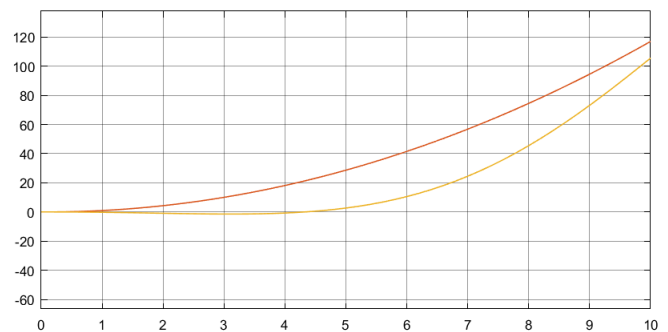

Figure 34: Altitude non-linear model (Orange) vs. Altitude linear model (Yellow)

### C. Stability

The eigen values of matrix A are calculated to determine the system's stability. If any eigen value is positive or has positive real part, the system is unstable.

The results for this system, shown in Figure 35, indicate that it is unstable.

```

>> eig(A)

ans =

    0.0000 + 0.0000i
    0.0000 + 0.0000i
    0.0000 + 0.0000i
    0.0000 + 0.0000i
    0.0000 + 0.0000i
    0.0000 + 0.0000i
    0.0000 + 0.0000i
    0.0000 + 0.0000i
    0.0000 + 0.0000i
    0.0000 + 0.0000i
   -0.1481 + 0.1481i
   -0.1481 - 0.1481i
    0.1481 + 0.1481i
    0.1481 - 0.1481i

```

Figure 35: Eigen values of matrix A

#### D. Sensitivity analysis

The results of the analysis show that the maximum height reached was 331, 7001 m. This result was obtained with the following parameter configuration:

- Weight of the rocket:  $m = 419.5747kg$
- Height of the rocket:  $h = 3.2673m$
- Main engine force:  $F_{mld} = 21515N$
- Thruster engine force:  $F_{lat} = 1381N$

This parameter values are very close to those employed in the model by the document, showing that they are consistent results, as shown in figure 36.

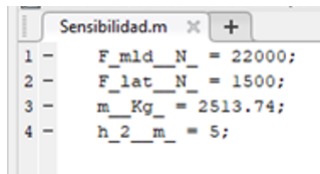

```

Sensibilidad.m
1 - F_mld_N = 22000;
2 - F_lat_N = 1500;
3 - m_Kg = 2513.74;
4 - h_2_m = 5;

```

Figure 36: Parameters of the model described in the paper

On the other hand, the analysis shows a tendency to reduce the size and weight of the rocket, showing that these two parameters are the most sensitive in the model. These two parameters of the rocket were developed in order to observe how capacity (weight) and height could be redistributed in order to maximize the height. But often, the physical characteristics of the rocket cannot be altered since most simulations have a predefined prototype of rocket.

F_lat_N	F_mld_N	h_2_m	m_Kg	MaxHeight
1.3333e+03	1.9123e+04	4.1702	1.9760e+03	0
1.3811e+03	2.1515e+04	3.2673	419.5747	331.7001
1.1127e+03	2.1415e+04	4.4507	1.2375e+03	56.3891
1.3860e+03	1.9971e+04	4.6367	505.3101	237.0448
1.2652e+03	2.0736e+04	4.1984	732.9126	147.6062
1.0988e+03	1.9065e+04	4.3039	2.1340e+03	0
1.1669e+03	1.9837e+04	4.2832	1.9602e+03	2.5659
1.2393e+03	2.1179e+04	3.8857	1.3242e+03	49.3481
1.4202e+03	2.0711e+04	4.1699	2.3156e+03	0
1.4274e+03	2.1431e+04	3.5851	436.4570	314.1051

Figure 37: Sensitivity analysis results

## IV. CONCLUSIONS

- It was possible to model the rocket's take-off trajectories. As the model's results show, it is possible to predict how the rocket will move. Launch predictions are used to free both maritime and aerial space, which is required by government regulations. This is beneficial since it reduces the probability of fatalities; defines precise clearance areas, which translates into smaller areas with flight navigation restrictions, which in turn avoids flight cancellation, delayed port arrivals and other economic activities that are possibly affected; and finally, it saves important R& D resources.
- Simulating take-off on different configurations made it possible to understand how the rocket will behave on different environments. The results clearly show which policy will perform better on different scenarios, which means a lower failure probability while the rocket is taking-off vertically. Since most of the current research objectives focus on reusable rockets, that can reliably and autonomously take-off and land, the results are an important resource to those trying to do this kind of simulations on hardware.
- Through linearization, assuming everything is zero except on the X-axis (ascending axis), an equivalent model of the previously proposed non-linear model could be obtained. Once a linear model is accomplished, it can be used to solve and analyze by a variety of methods. This means that simulations can be easily done to show system's behavior as time changes. This is a desired behavior since it is critical to understand how the rocket will behave as it is ascending.
- Making use of sensitivity analysis the parameters that maximized our objective (reach the highest elevation of the rocket during take-off) are able to be estimated. The results clearly showed which combination of force from the main motor and the lateral motors (thrusters) worked best, as well as the best proportions of mass and height for the rocket. The histograms used to plot the results have clear trends and therefore can be taken as a reliable source. The data generated from this analysis can be further used to explore rocket design and determine precise launch schedules, since the trajectory of the rocket is easily and reliably determined.

#### A. Future Work:

Further development could focus on:

- Extend the model to consider aerodynamic phenomena, gravitational fields and planet-moon rotation.
- Test different rocket shapes and engines configurations.
- Employ more advanced modelling techniques such as Reinforcement Learning (RL) along with the Dynamical Model to generate better vertical take-off policies.
- A more ambitious, and economically sound policy would be to generate a landing policy.
- Using the results off this work, it is possible to explore more rocket configurations and even extend it to analyze aerodynamic performance or fuel efficiency.

## REFERENCES

[1] Faruqi, F. A., & Vu, T. L. (2002). Mathematical models for a missile autopilot design (No. DSTO-TN-0449). DEFENCE SCIENCE AND TECHNOLOGY ORGANISATION CANBERRA (AUSTRALIA).  
 [2] Mahlstedt, B. (2012). Optimal VTOL of SpaceX's Grasshopper.