

Brief Description of Scope: 2420 sq ft 4 bed/3 bath

Brief Description of Scope: 2420 sq ft 4 bed/3 bath			
BUDGET ITEM	DESCRIPTION	AMOUNT	NOTAS
earnest money		\$ -	
<b>DEVELOPMENT COSTS</b>			
Plans, Architect Fees		\$ -	
survey		\$ -	
site plan		\$ -	
Permits (fee atlanta)		\$ -	
license		\$ -	
expediteior		\$ -	
<b>FUNDATION/ DEMOLITION</b>			
Dumpsters & Trashout (3)	\$ 3	\$ 2,500.00	
Seal Fence		\$ 2,500.00	
temporal post		\$ 920.00	
permit electriciti		\$ 1,000.00	
Find and connection sewer clean out		\$ 2,900.00	IMPORTANTE SABER SI EL LOTE TIENE LOS UTILITIES AVALIBLES
Demolition Labor and Equipment			
Grading, Site Prep	mark house/ trinceras	\$ 3,061.17	
Foundation/ Labor/ Material		\$ 38,000.00	
<b>STRUCTURE</b>			
Roof Trusses			
Framing material		\$ 45,000.00	
Structure repair, replacing rotten wood			
Fraiming labor		\$ 25,000.00	
Retaining Walls			
<b>EXTERIOR</b>			
Roofing	(Material)	\$ 6,800.00	
Flashing		\$ 350.00	
Windows		\$ 15,000.00	
Siding	(Type)	\$ 25,000.00	
Brick, masonry			
Stucco		\$ 1,500.00	
Soffits, Fascia, Trim		\$ 3,000.00	

Gutters, Downspouts		\$ -	
Exterior doors		\$ 2,500.00	
Garage Door(s)		\$ -	
Decks		\$ 8,000.00	
<b>HVAC</b>			
Rough HVAC		\$ 6,000.00	
Trim HVAC			
Final HVAC		\$ 6,000.00	
<b>PLUMBING</b>			
Rough plumbing		\$ 7,000.00	
Trim plumbing		\$ -	
Final plumbing		\$ 7,000.00	
Plumbing Fixtures		-	TODO DEPENDE DE LA LISTA QUE ENVIARON EL PRECIO
Water heater		\$ 1,200.00	
<b>ELECTRICAL</b>			
Rough electrical		\$ 6,000.00	
Trim electrical		\$ -	
Final electrical		\$ 6,000.00	
Electrical/lighting fixtures		-	TODO DEPENDE DE LA LISTA QUE ENVIARON
<b>FINISHES</b>			
Insulation		\$ 4,000.00	
Drywall, Tape		\$ 12,000.00	
Interior Trim material and labor	material and labor	\$ 15,000.00	
Interior doors			
Finish Carpentry			
Hardware		\$ 560.00	TODO DEPENDE DE LO QUE ESCOGIERON EN LA LISTA
<b>KITCHEN</b>			
Kitchen Tile AND LABOR		\$ 600.00	
Kitchen cabinets	<i>(new construction or refacing)</i>	\$ 8,000.00	
Kitchen appliances		\$ 5,500.00	
Kitchen countertops	<i>GRANITE</i>	\$ 4,500.00	
<b>BATHROOMS</b>			
Bath vanities/ Mirrors		\$ 800.00	TODO DEPENDE DE LA LISTA QUE ENVIARON
Bathroom Labor		\$ 8,000.00	

Tubs / Toilets / Sinks				\$ 1,200.00	
Bathroom Countertops					
<b>PAINT</b>					
Interior paint				\$ 6,000.00	
Exterior paint				\$ 6,000.00	
<b>FLOORING</b>					
Carpet	Sq Ft:				
Ceramic Stone Tile	Sq Ft:				
Vinyl	Sq Ft:				
Hardwood Floors	Sq Ft:			\$ 12,000.00	
Hardwood refinish	Sq Ft:				
Laminate	Sq Ft:				
<b>OUTDOOR/LANDSCAPING</b>					
Cleanup				\$ 800.00	
Landscaping				\$ 8,000.00	DEPENDE DEL LOTE CONDICIONES Y DIMENSIONES
Grading				\$ 1,800.00	
Water Lines/Sewer Lines					
Tree removal/Arborist				\$ 2,100.00	
Fencing					
Lawn care					
Paving/Walkways					
Driveway				\$ 4,500.00	
<b>MISCELLANEOUS</b>					
Gas				\$ -	
0					
0					
0					
0					
0					
<b>SUBTOTAL</b>				\$ 323,591.17	
Contingency			10% Recommended	\$ 10,000.00	
<b>TOTAL</b>				\$ 333,591.17	

# NEW CONSTRUCTION

103 14th Street  
Cumming, GA 30043

**SCOPE OF WORK:**

New construction of 4/3 SFR on crawlspace,  
with front porch and rear deck.

**SQUARE FOOTAGE:**

Proposed First Floor: 1124 sf  
Proposed Second Floor: 997 sf  
Proposed Porch: 100 sf  
Proposed Deck: 171 sf

**PROPOSED TOTAL: 2420 sf**

Layout Page Table	
Label	Title
A0	Cover Sheet
A0.1	General Notes
A1.1	Proposed Elevations
A1.2	Proposed Elevations
A1.3	Proposed Floor Plan
A1.4	Door-Window Schedule
S1.1	Foundation Plan
S1.2	Floor Framing
S1.3	Ceiling Framing
S1.4	Roof Framing
S1.5	Roof Plan
S1.6	Wall Sections
D1	Deck Framing
D2	Deck Framing
S1.7	Load Calculations
S1.8	Load Calculations
S1.9	Load Calculations
S1.10	Load Calculations
S1.11	Load Calculations
S1.12	Load Calculations
S1.13	Load Calculations

29'-1 1/2"



**Current Mandatory Codes as Adopted by DCA:**

- International Building Code, 2018 Edition, with Georgia Amendments (2020), (2022)
- International Residential Code, 2018 Edition, with Georgia Amendments (2020)
- International Fire Code, 2018 Edition (Contact State Fire Marshal Below)
- International Plumbing Code, 2018 Edition, with Georgia Amendments (2020), (2022), (2023)
- International Mechanical Code, 2018 Edition, with Georgia Amendments (2020)
- International Fuel Gas Code, 2018 Edition, with Georgia Amendments (2020), (2022)
- National Electrical Code, 2020 Edition, with Georgia Amendments (2021)
- International Energy Conservation Code, 2015 Edition, with Georgia Supplements and Amendments (2020), (2022), (2023)
- International Swimming Pool and Spa Code, 2018 Edition, with Georgia Amendments (2020)
- **For information and questions regarding the Life Safety Code (NFPA 101), IFC Georgia Amendments or the Georgia Accessibility Code please contact the State Fire Marshal's Office** [↗](#).

NUMBER	DATE	REVISION TABLE	REVISOR	DESCRIPTION

RELEASED FOR  
CONSTRUCTION

NEW CONSTRUCTION  
103 14th Street  
Cumming, GA 30043



DATE:  
6/13/2023

SCALE:

SHEET:  
A0

# NEW CONSTRUCTION

103 14th Street  
Cumming, GA 30040

## CONSTRUCTION AND FRAMING NOTES

1. DESIGN LOADS ARE AS FOLLOWS PER SQ. FT.

LOCATION	LIVE	DEAD	DEFLECT LIMIT
1 <sup>ST</sup> FLOOR	40 LB	10 LB	L/360
2 <sup>ND</sup> FLOOR (SLEEPING AREA)	30 LB	10 LB	L/360
ATTIC (NON STORAGE)	10 LB	5LB	L/240
ATTIC (STORAGE)	20 LB	10 LB	L/240
ROOF (W/ FINISHED CEILING)	30 LB	15 LB	L/240
ROOF( NO FINISHED CEILING)	30 LB	7LB	L/180
DECKS	60 LB	10LB	L/360

SNOW LOADS HAVE BEEN ADJUSTED TO REFLECT THE SLIDE OFF FACTOR AS A FUNCTION OF ROOF PITCH. RAFTER SIZES MAY HAVE TO BE INCREASED TO ACCOMMODATE HIGHER SNOW LOADS. VERIFY WITH LOCAL CODES.

2. LUMBER SHALL BE DOUGLAS-FIR-LARCH, HEM-FIR, OR SOUTHERN YELLOW PINE WITH FB=1450 AND E=1.6 MINIMUM.

ALL PRESSURE TREATED LUMBER WILL BE A MINIMUM OF SYP#2 WITH A MOISTURE CONTENT OF 19%

3. ALL HEADERS SHALL BE FREE FROM ALL SPLITS, CHECKS, OR SHAKES.

4. UNLESS NOTED OTHERWISE, PROVIDE DOUBLE HEADER JOISTS AND TRIMMERS AT ALL FLOOR OPENINGS, DOUBLE JOISTS UNDER ALL PARALLEL PARTITIONS, DOUBLE 2X12 HEADERS WITH 1/2" PLYWOOD, GLUED BETWEEN AND NAILED, FOR ALL OPENINGS IN 2X6 WALLS. DOUBLE 2X12 HEADERS NAILED TOGETHER FOR ALL OPENINGS IN 2X4 WALLS.

5. FLOOR CONSTRUCTION: 3/4" TONGUE AND GROOVE SUBFLOOR WITH FINISH MATERIAL OVER.

6. STAIR CONSTRUCTION SHALL CONSIST OF (3) 2X2 STRINGERS, 5/4" OR 2X THICK TREADS AND 3/4" THICK RISERS OR MATERIALS FABRICATED BY A COMPONENT MANUFACTURER.

7. ALL WOOD PLATES IN CONTACT WITH CONCRETE SHALL BE PRESSURE TREATED AND SILICONE SEALED.

8. MICRO-LAM BEAMS SHALL HAVE BENDING STRESS: FB=2800 PSI. VERIFY WITH LOCAL CODES.

9. SPECIAL UPLIFT CONNECTORS AS INDICATED AT CANTILEVERED JOISTS SHALL BE SIMPSON STRONG TIE ANCHORS OR EQUAL.

10. MINIMUM HEADER SIZE SHALL BE (2) 2"x6" UNLESS NOTED OTHERWISE EXTERIOR WALLS SHALL BE (2) 2X12 WITH 1/2" PLYWOOD.

11. ALL STRUCTURAL STEEL SHALL CONFORM WITH ASTM SPECIFICATION A-36.

12. UNLESS OTHERWISE NOTED, PROVIDE A 2X PLATE BOLTED TO THE TOP FLANGE OF ALL STEEL BEAMS WITH 3/8" DIAMETER BOLTS STAGGERED AT 24" ON CENTER. RIGIDLY FASTEN ALL CONNECTING RAFTERS AND JOISTS AS APPROVED BY GOVERNING CODES, UNLESS OTHERWISE NOTED.

13. FLOOR FRAMING LAYOUT SHALL BE COORDINATED WITH THE GENERAL AND HVAC CONTRACTORS TO PROVIDE ACCESS CHASES AND UNOBSTRUCTED RUNS FOR HVAC DUCT WORK. FLOOR TRUSS LAYOUT TO BE ENGINEERED BY TRUSS MANUFACTURE.

14. PROVIDE BRIDGING OR BLOCKING AT MIDSPAN OF JOISTS/RAFTERS/TRUSSES. MAXIMUM SPACING BETWEEN BEARING WALL AND BLOCKING IS 8'0".

15. THESE FRAMING PLANS WERE DESIGNED USING STANDARD CONSTRUCTION PRACTICES. THEY CONFORM TO STANDARD BUILDING CODES. DUE TO VARIATIONS IN LOCAL CODES AND GEOLOGICAL CONDITIONS REVISIONS MAY BE REQUIRED TO THESE PLANS.

16. ALL WORK SHALL BE PERFORMED IN ACCORDANCE WITH ALL APPLICABLE LOCAL CODES. REGULATIONS AND FHA/VA MPS. THE BUILDER SHALL VERIFY ALL CONDITIONS WITH LOCAL STRUCTURAL ENGINEERS AND CODE OFFICIALS PRIOR TO USING THE FRAMING MATERIALSPROVIDED TO INSURE COMPLIANCE WITH CODES AND STRUCTURAL INTEGRITY.

17. ALL CONCRETE SHALL HAVE A MINIMUM COMPRESSIVE STRENGTH OF 3000 PSI

## NOTE:

1. HVAC TO BE IN ATTIC. VERIFY WITH BUILDER.

2. UPPER FLOOR CEILING HEIGHTS TO BE 8'0" UNLESS NOTED.

3. UPPER FLOOR JOISTS TO BE 16 1/2" OPEN WEB FLOOR.

TRUSSES AT 16"OC w/3/4 T&G ADVANTECH FLOOR GLUED AND SCREWED. SEE TRUSS MANUFACTURER FOR FLOOR TRUSS LAYOUTS. ALL OPEN WEB FLOOR TRUSSES TO BE DESIGNED AND ENGINEERED BY TRUSS MANUFACTURER. TRUSS MANUFACTURER WILL PROVIDE TRUSS LAYOUT BASED ON ENGINEERING.

TRUSS MANUFACTURER TO SUPPLY TRUSSES WITH CHAMFERED END ON SELECTED UNITS TO ALLOW FOR EXTERIOR WALL SUPPORT AND RATER CLEARANCE.

4. HVAC AND WATER HEATER TO BE IN ATTIC UNLESS OTHERWISE NOTED.

## ELEVATION NOTES:

1. GUTTERS AND DOWNSPOUTS ARE NOT SHOWN FOR CLARITY. DOWNSPOUTS SHALL BE LOCATED TOWARDS THE FRONT AND REAR OF THE HOUSE. LOCATE DOWNSPOUTS IN NON-VISUALLY OFFENSIVE LOCATIONS. FOR EXAMPLE, FRONT WALL OF HOUSE BESIDE PORCH COLUMNS, ETC. GENERAL CONTRACTOR SHALL VERIFY EXISTING GRADES AND COORDINATE ANY NECESSARY ADJUSTMENTS TO HOUSE WITH OWNER.

2. PLUMBING AND HVAC VENTS SHALL BE GROPED IN ATTIC TO LIMIT ROOF PENETRATIONS AND TO BE LOCATED AWAY FROM PUBLIC VIEW. I.E. AT THE REAR OF THE HOUSE AND SHALL BE PRIMED AND PAINTED TO MATCH ROOF COLOR.

3. PROVIDE ATTIC VENTILATION PER LOCAL CODE REQUIREMENTS.

4. EXTERIOR FLASHING SHALL BE CORRECTLY INSTALLED AT ALL CONNECTIONS BETWEEN ROOFS, WALLS, CHIMNEYS, PROJECTIONS, AND PENETRATIONS AS REQUIRED BY APPROVED CONSTRUCTION PRACTICES.

5. CONTRACTOR SHALL PROVIDE ADEQUATE ATTIC VENTILATIONS ROOF VENTS PER LOCAL GOVERNING CODE. INSTALL CONTINUOUS RIDGE VENTILATION AND PAINT TO MATCH ROOF. PROVIDE APPROPRIATE SOFFIT VENTILATION AT OVERHANGS.

## FRAMING NOTES:

1. RAFTERS TO BE SUPPORTED BY CONTINUOUS BRACING FOR HORIZONTAL SPANS OF 15'0" OR GREATER.

2. SUPPORT ALL HIP, VALLEY, AND RIDGES @ 8'0" OC MAX.

3. ALL RAFTERS TO BEAR ON SECOND FLOOR WALLS WHERE APPLICABLE.

4. RAFTERS MAY BE SPLICED ONLY @ CONT. BRACING OR SECOND FLOOR WALLS.

5. RAFTERS TO BE PLACED IN COMPLIANCE WITH ALL LOCAL CODES. EXAMPLES:

2X6 RAFTER@16"OC MAX WITH 1/2" P W DECKING

2X6 RAFTERS @ 24"OC MAX WITH 5/8"P W DECKING

2X8 RAFTERS @ 24"OC MAX WITH 5/8"P W DECKING

2X8 RAFTERS @ 16"OC MAX WITH 1/2" P W DECKING

6. FASCIA OVERHANG TO BE 12" (TYPICAL) UNLESS NOTED ON ELEVATIONS.

7. ALL HIP/VALLEY RAFTERS TO BE 2X10 UNLESS NOTED.

## NOTE:

PURLINS ARE PERMITTED TO BE INSTALLED TO REDUCE THE SPAN OF RAFTERS. PURLINS SHALL BE SUPPORTED BY 2 INCH X 4 INCH BRACES INSTALLED TO BEARING WALLS AT A SLOPE OF NOT LESS THAN 45 DEGREES. THE BRACES SHALL NOT BE SPACED MORE THAN 48" APART ON CENTER AND THE UNBRACED LENGTH OF BRACES SHALL NOT EXCEED 8 FT. PURLINS SHALL BE CONTINUOUS (REFER IRC R802.5.1)

## FLOOR PLANS NOTES:

1. ALL STRUCTURAL INFORMATION SHOWN FOR REFERENCE PURPOSES ONLY. CONTRACTOR SHALL HAVE LICENSED STRUCTURAL ENGINEER REVIEW AND DESIGN ALL STRUCTURAL ELEMENTS SUCH AS ALL FRAMING WALLS, BEAMS, CONNECTIONS, HEADERS, JOISTS, AND RAFTERS.

2. ALL DIMENSIONS ARE FROM FACE OF STUD TO FACE OF STUD UNLESS NOTED OTHERWISE.

3. WINDOW SIZES INDICATED ON PLANS ARE NOTED BY APPROXIMATE ROUGH OPENING SIZE; REFER TO PLANS AND EXTERIOR ELEVATIONS FOR WINDOW TYPES.

4. COORDINATE LOCATION OF UTILITY METERS WITH SITE PLAN AND LOCATE AWAY FROM PUBLIC VIEW. VISUAL IMPACT SHALL BE MINIMIZED, I.E. MOUNT AS LOW AS POSSIBLE.

5. PREFABRICATED FIREPLACE CONSTRUCTION SHALL MEET OR EXCEED ALL APPLICABLE CODES REGARDING USE OF FIRE SEPARATIONS, CLEARANCES, ETC. IT IS THE CONTRACTOR'S RESPONSIBILITY TO ENSURE THAT ALL ITEMS AND CONSTRUCTION MEET OR EXCEED CODE. OVERALL FLUE HEIGHT SHALL BE COORDINATED TO MATCH HEIGHT SHOWN ON PLANS AND SHALL NOT EXCEED THE TOP OF CHIMNEY CHASES AS CONSTRUCTED.

6. CONTRACTOR SHALL COORDINATE ALL CLOSET SHELIVING REQUIREMENTS.

7. DO NOT SCALE DRAWINGS. FOLLOW DIMENSIONS.

8. CONTRACTOR SHALL FIELD VERIFY ALL CABINET DIMENSIONS BEFORE FABRICATION.

9. BEDROOM WINDOWS SHALL HAVE A MINIMUM NET CLEAR OPENING OF 5.7 SQ FT. A MINIMUM NET CLEAR OPENABLE WIDTH OF 20", A MINIMUM NET CLEAR OPENABLE HEIGHT OF 24" AND HAVE A MAXIMUM FINISH SILL HEIGHT OF 43" FROM FINISH FLOOR.

10. ALL GLASS LOCATED WITHIN 18" OF FLOOR, 12" OF A DOOR OR LOCATED WITHIN 60" OF FLOOR AT BATHTUBS, WHIRLPOLS, SHOWERS, SAUNAS, STEAM ROOMS, OR HOT TUBS SHALL BE TEMPERED.

11. ALL EXPOSED INSULATION SHALL HAVE A FLAME SPREAD RATING OF LESS THAN 25 AND A SMOKE DENSITY RATING OF LESS THAN 450.

12. PROVIDE COMBUSTION AIR VENTS, WITH SCREEN AND BACK DAMPER, FOR FIREPLACES, WOOD STOVES AND ANY APPLIANCE WITH AN OPEN FLAME.

13. BATHROOMS AND UTILITY ROOMS SHALL BE VENTED TO THE OUTSIDE WITH A MINIMUM OF A 90 CFM FAN. RANGE HOODS SHALL ALSO BE VENTED TO OUTSIDE.

14. ATTIC HVAC UNITS SHALL BE LOCATED WITHIN 20' OF ITS SERVICE OPENING. RETURN AIR GRILLES SHALL NOT BE LOCATED WITHIN 10 FEET OF A GAS FIRED APPLIANCE.

15. ALL WALLS AND CEILINGS IN GARAGE AND GARAGE STORAGE AREAS TO HAVE 5/8 TYPE X GYPSUM BOARD WITH 1 HOUR FIRE RATING. ALL EXTERIOR DOORS IN GARAGE TO BE METAL OR SOLID CORE DOORS, INCLUDING DOORS ENTERING HEAT/COOLED PORTION OF RESIDENCE.

16. ALL FIREPLACE CHASE WALLS SHALL BE INSULATED INSIDE AND OUTSIDE. PROVIDE HORIZONTAL "DRAFT STOPS" AT EACH FLOOR LEVEL BY PACKING 6"(R-19) INSULATION BETWEEN 2X4 JOISTS.

17. ALL INTERIOR WALLS SHALL BE COVERED WITH 1/2" GYPSUM BOARD WITH METAL CORNER REINFORCING, TAPE FLOAT, AND SAND (3 COATS). USE 5/8" GYPSUM BOARD ON CEILINGS WHEN SUPPORTING MEMBERS ARE 24"OC OR GREATER. USE 1/2" GYPSUM BOARD ON CEILINGS WHEN SUPPORTING MEMBERS LESS THAN 24"OC.

18. ALL BATH AND TOILET AREA WALLS AND CEILINGS SHALL HAVE WATER RESISTANT GYPSUM BOARD.

NUMBER	DATE	REVISION TABLE	REVISED BY	DESCRIPTION

RELEASED FOR  
CONSTRUCTION

NEW CONSTRUCTION  
103 14th Street  
Cumming, GA 30043



DATE:

6/13/2023

SCALE:

SHEET:

A0.1



Proposed Front Elevation  
Scale: 1/8" = 1'

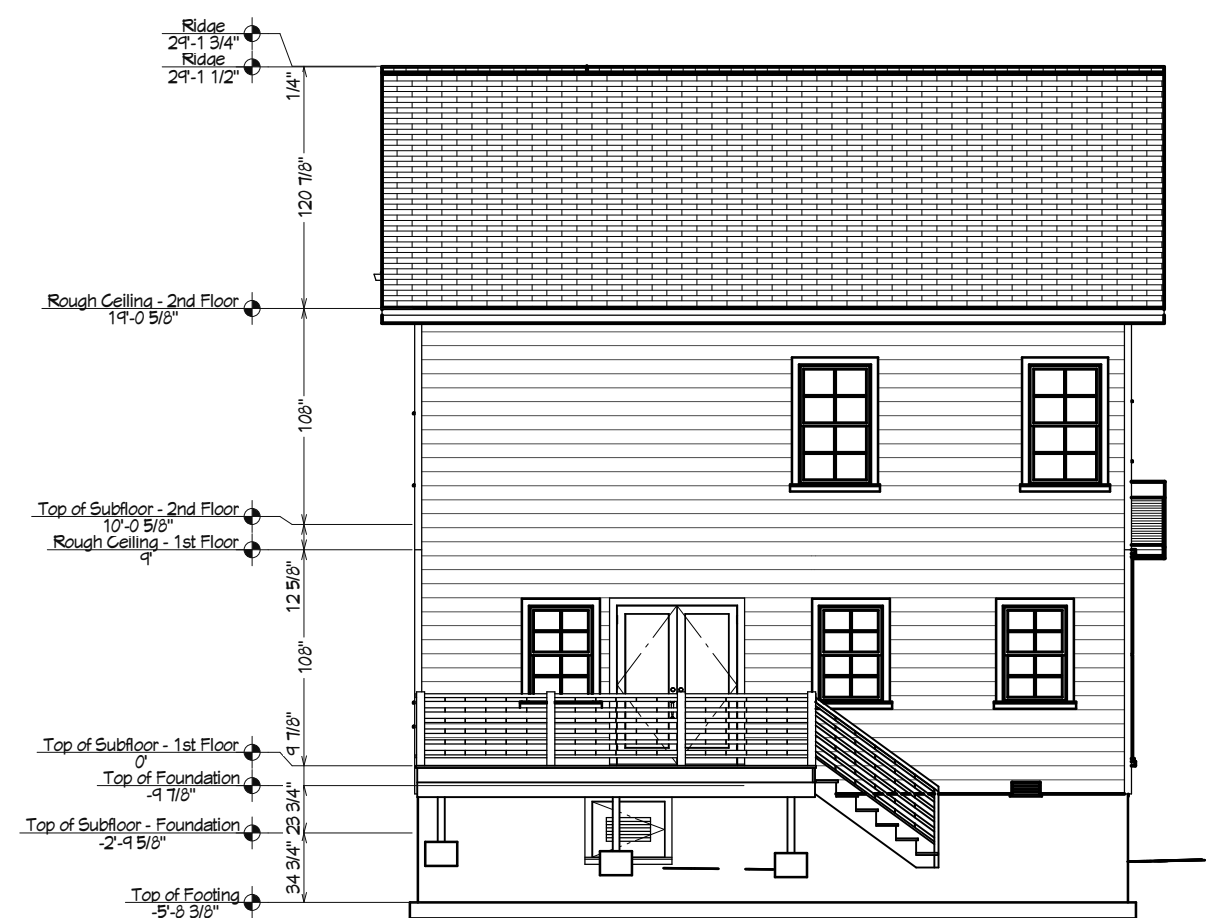

Proposed Rear Elevation  
Scale: 1/8" = 1'

NUMBER	DATE	REVISION TABLE	REVISED BY	DESCRIPTION

RELEASED FOR  
CONSTRUCTION

NEW CONSTRUCTION  
103 14th Street  
Cumming, GA 30043



DATE:

6/13/2023

SCALE:

SHEET:

A1.1



Proposed Left Elevation  
Scale: 1/8" = 1'



Proposed Right Elevation  
Scale: 1/8" = 1'

NUMBER	DATE	REVISION TABLE	REVISED BY	DESCRIPTION

RELEASED FOR  
CONSTRUCTION

NEW CONSTRUCTION  
103 14th Street  
Cumming, GA 30043



DATE:

6/13/2023

SCALE:

SHEET:

A1.2

9' CEILING HEIGHT

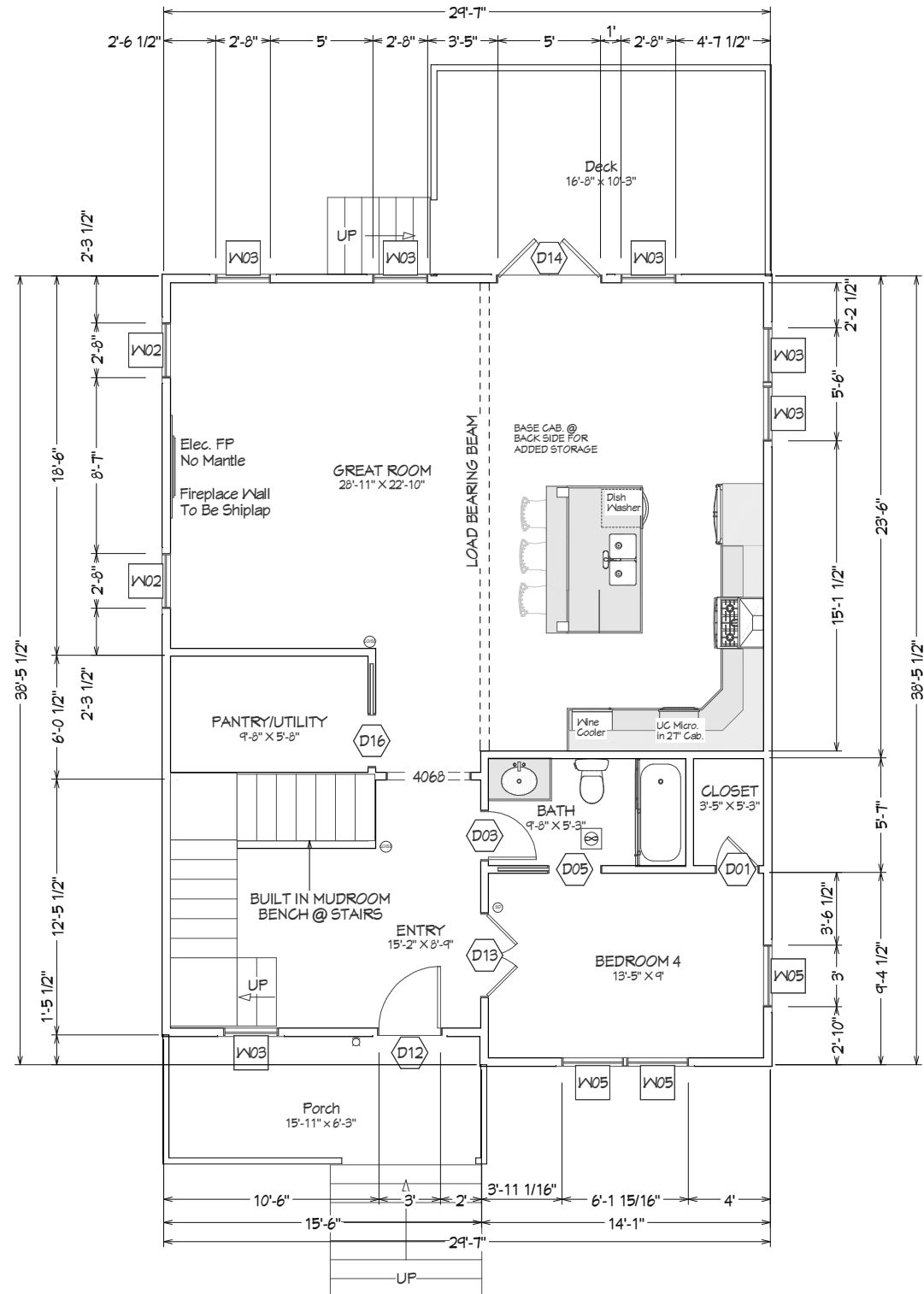

Proposed First Floor  
Scale: 1/8" = 1'

9' CEILING HEIGHT

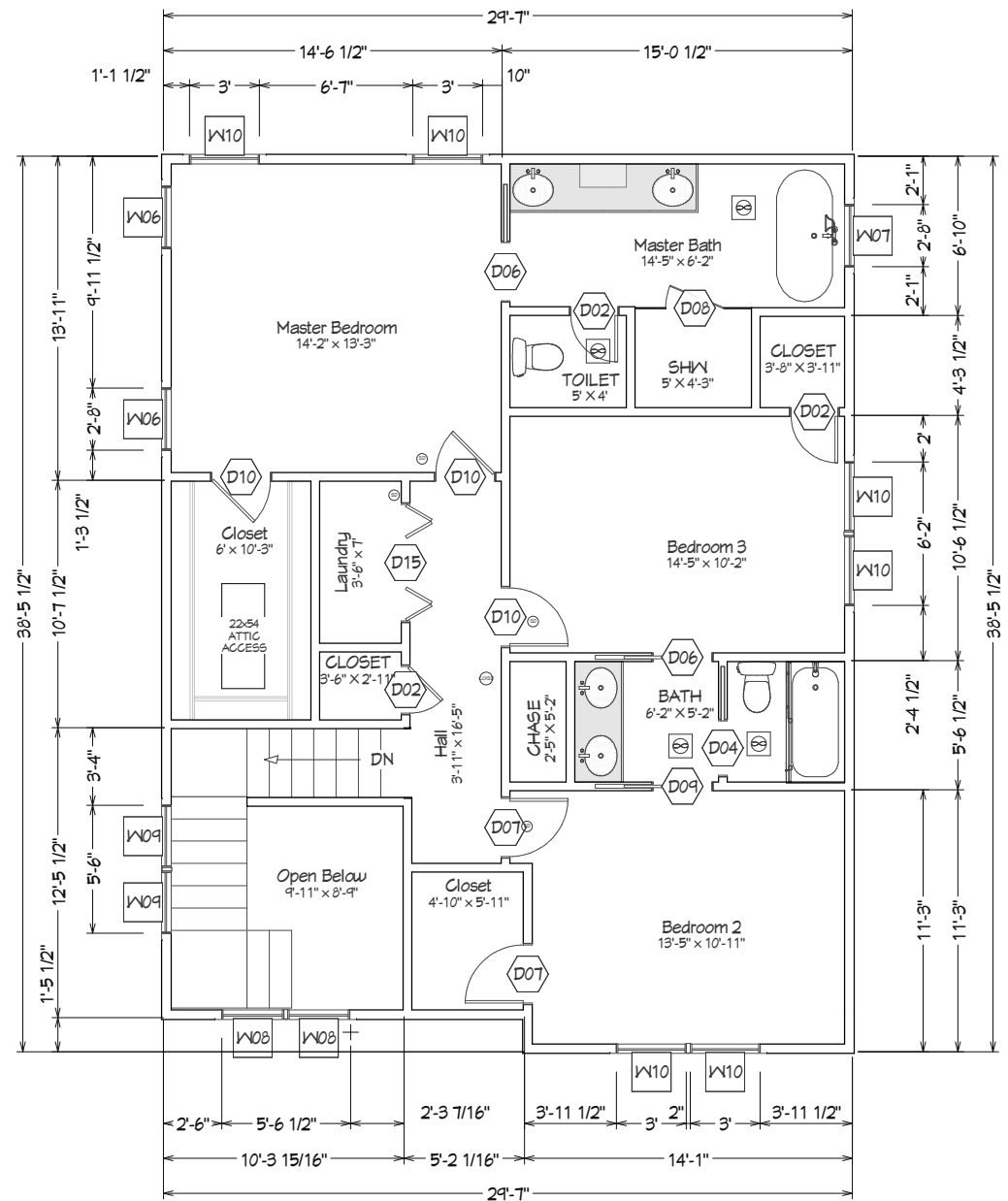

Proposed Second Floor  
Scale: 1/8" = 1'

NUMBER	DATE	REVISION TABLE	REVISOR	DESCRIPTION

RELEASED FOR  
CONSTRUCTION

NEW CONSTRUCTION  
103 14th Street  
Cumming, GA 30043



DATE:  
6/13/2023

SCALE:

SHEET:

A1.3

**DOOR SCHEDULE**

NUMBER	LABEL	QTY	FLOOR	SIZE	WIDTH	HEIGHT	R/O	DESCRIPTION	HEADER	THICKNESS	FIRE
D01	2068	1	1	2068 R IN	24 "	80 "	26"X82 1/2"	HINGED-PANEL	2X6X29" (2)	1 3/8"	
D02	2068	3	2	2068 L IN	24 "	80 "	26"X82 1/2"	HINGED-PANEL	2X6X29" (2)	1 3/8"	
D03	2468	1	1	2468 R IN	28 "	80 "	30"X82 1/2"	HINGED-PANEL	2X6X33" (2)	1 3/8"	
D04	2468	1	2	2468 R	28 "	80 "	57 1/4"X82 1/2"	POCKET-PANEL	2X6X60 1/4" (2)	1 3/8"	
D05	2668	1	1	2668 L	30 "	80 "	61 1/4"X82 1/2"	POCKET-PANEL	2X6X64 1/4" (2)	1 3/8"	
D06	2668	2	2	2668 L	30 "	80 "	61 1/4"X82 1/2"	POCKET-PANEL	2X6X64 1/4" (2)	1 3/8"	
D07	2668	2	2	2668 L IN	30 "	80 "	32"X82 1/2"	HINGED-PANEL	2X6X35" (2)	1 3/8"	
D08	2668	1	2	2668 R	30 "	80 "	30"X80"	SHOWER-GLASS SLAB		1/2"	
D09	2668	1	2	2668 R	30 "	80 "	61 1/4"X82 1/2"	POCKET-PANEL	2X6X64 1/4" (2)	1 3/8"	
D10	2668	3	2	2668 R IN	30 "	80 "	32"X82 1/2"	HINGED-PANEL	2X6X35" (2)	1 3/8"	
D11	3024	1	0	3024 R EX	36 "	27 11/16 "	38"X30 11/16"	EXT. HINGED-DOOR S03	2X6X38" (2)	1 3/4"	
D12	3068	1	1	3068 R EX	36 "	80 "	38"X83"	EXT. HINGED-DOOR E21	2X6X41" (2)	1 3/4"	
D13	4068	1	1	4068 L/R IN	48 "	80 "	50"X82 1/2"	DOUBLE HINGED-PANEL	2X8X53" (2)	1 3/8"	
D14	5068	1	1	5068 L/R EX	60 "	80 "	62"X83"	EXT. DOUBLE HINGED-DOOR F01	2X8X65" (2)	1 3/4"	
D15	5068	1	2	5068 L/R	60 "	80 "	62"X82 1/2"	4 DR. BIFOLD-PANEL	2X8X65" (2)	1 3/8"	
D16	2668	1	1	2668 R	30 "	80 "	61 1/4"X82 1/2"	POCKET-PANEL	2X6X64 1/4" (2)	1 3/8"	

**WINDOW SCHEDULE**

NUMBER	LABEL	QTY	FLOOR	SIZE	WIDTH	HEIGHT	R/O	EGRESS	DESCRIPTION	HEADER	TEMPERED
W01	1220	2	3	1220	14 "	24 "	15"X25"		LOUVERED	2X6X18" (2)	
W02	W1	2	1	2820FX	32 "	24 "	33"X25"		FIXED GLASS	2X6X36" (2)	
W03	W1	6	1	2840DH	32 "	48 "	33"X49"		DOUBLE HUNG	2X6X36" (2)	
W05	W1	3	1	3050DH	36 "	60 "	37"X61"	YES	DOUBLE HUNG	2X6X40" (2)	
W06	W1	2	2	2816FX	32 "	18 "	33"X19"		FIXED GLASS	2X6X36" (2)	
W07	W1	1	2	2820FX	32 "	24 "	33"X25"		FIXED GLASS	2X6X36" (2)	YES
W08	W1	2	2	2840DH	32 "	48 "	33"X49"		DOUBLE HUNG	2X6X36" (2)	
W09	W1	2	2	2840DH	32 "	48 "	33"X49"	YES	DOUBLE HUNG	2X6X36" (2)	
W10	W1	6	2	3050DH	36 "	60 "	37"X61"	YES	DOUBLE HUNG	2X6X40" (2)	

REVISION TABLE	NUMBER	DATE	REVISION BY	DESCRIPTION

RELEASED FOR  
CONSTRUCTION

NEW CONSTRUCTION  
103 14th Street  
Cumming, GA 30043



DATE:

6/13/2023

SCALE:

SHEET:

A1.4



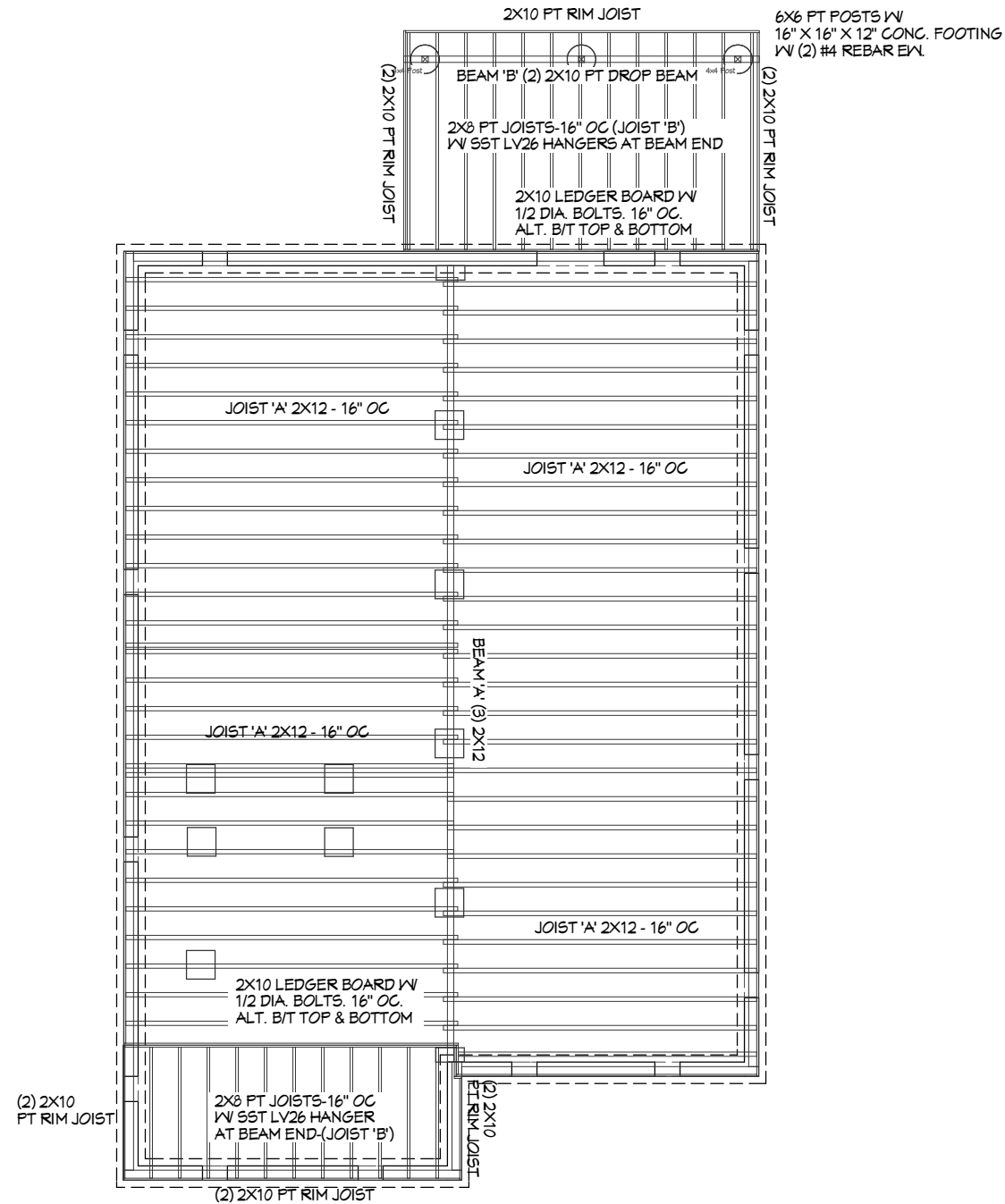

Floor Framing-First Floor  
Scale: 1/8" = 1'

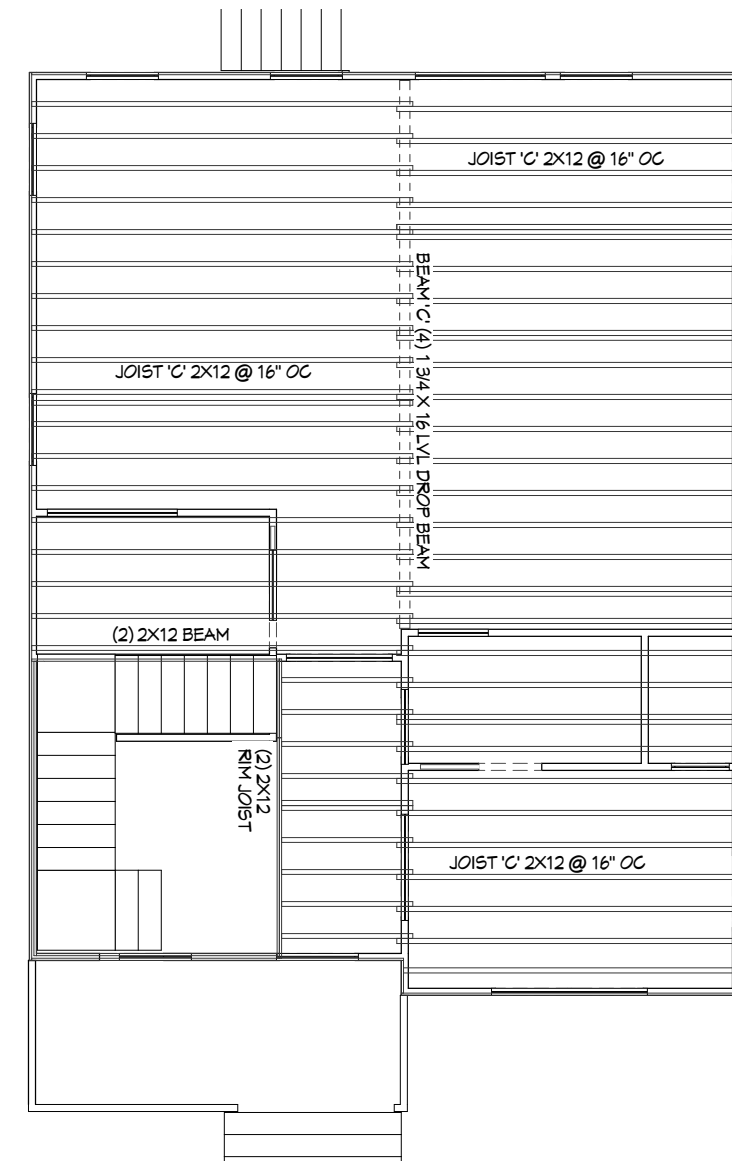

Floor Framing-Second Floor  
Scale: 1/8" = 1'

TABLE R502.3.1(2)  
FLOOR JOIST SPANS FOR COMMON LUMBER SPECIES (Residential living areas, live load = 40 psf, L/Δ = 360) <sup>b</sup>

JOIST SPACING (inches)	SPECIES AND GRADE	DEAD LOAD = 10 psf				DEAD LOAD = 20 psf				
		2 x 6	2 x 8	2 x 10	2 x 12	2 x 6	2 x 8	2 x 10	2 x 12	
		Maximum floor joist spans (ft. - in.)								
16	Southern pine	SS	10-2	13-4	17-0	20-9	10-2	13-4	17-0	20-9
	Southern pine	#1	9-9	12-10	16-1	19-1	9-9	12-7	14-8	17-5
	Southern pine	#2	9-4	11-10	14-0	16-6	8-6	10-10	12-10	15-1
	Southern pine	#3	7-1	8-11	10-10	12-10	6-5	8-2	9-10	11-8
	Spruce-pine-fir	SS	9-6	12-7	16-0	19-6	9-6	12-7	16-0	19-6
	Spruce-pine-fir	#1	9-4	12-3	15-5	17-10	9-1	11-6	14-1	16-3
	Spruce-pine-fir	#2	9-4	12-3	15-5	17-10	9-1	11-6	14-1	16-3
	Spruce-pine-fir	#3	7-6	9-6	11-8	13-6	6-10	8-8	10-7	12-4

TABLE R502.3.1(1)  
FLOOR JOIST SPANS FOR COMMON LUMBER SPECIES (Residential sleeping areas, live load = 30 psf, L/Δ = 360) <sup>a</sup>

JOIST SPACING (inches)	SPECIES AND GRADE	DEAD LOAD = 10 psf				DEAD LOAD = 20 psf				
		2 x 6	2 x 8	2 x 10	2 x 12	2 x 6	2 x 8	2 x 10	2 x 12	
		Maximum floor joist spans (ft. - in.)								
12"	Southern pine	SS	12-3	16-2	20-8	25-1	12-3	16-2	20-8	25-1
	Southern pine	#1	11-10	15-7	19-10	24-2	11-10	15-7	18-7	22-0
	Southern pine	#2	11-3	14-11	18-1	21-4	10-9	13-8	16-2	19-1
	Southern pine	#3	9-2	11-6	14-0	16-6	8-2	10-3	12-6	14-9

NUMBER	DATE	REVISION TABLE	REVISED BY	DESCRIPTION

RELEASED FOR CONSTRUCTION

NEW CONSTRUCTION  
103 14th Street  
Cumming, GA 30043



DATE:

6/13/2023

SCALE:

SHEET:

S1.2

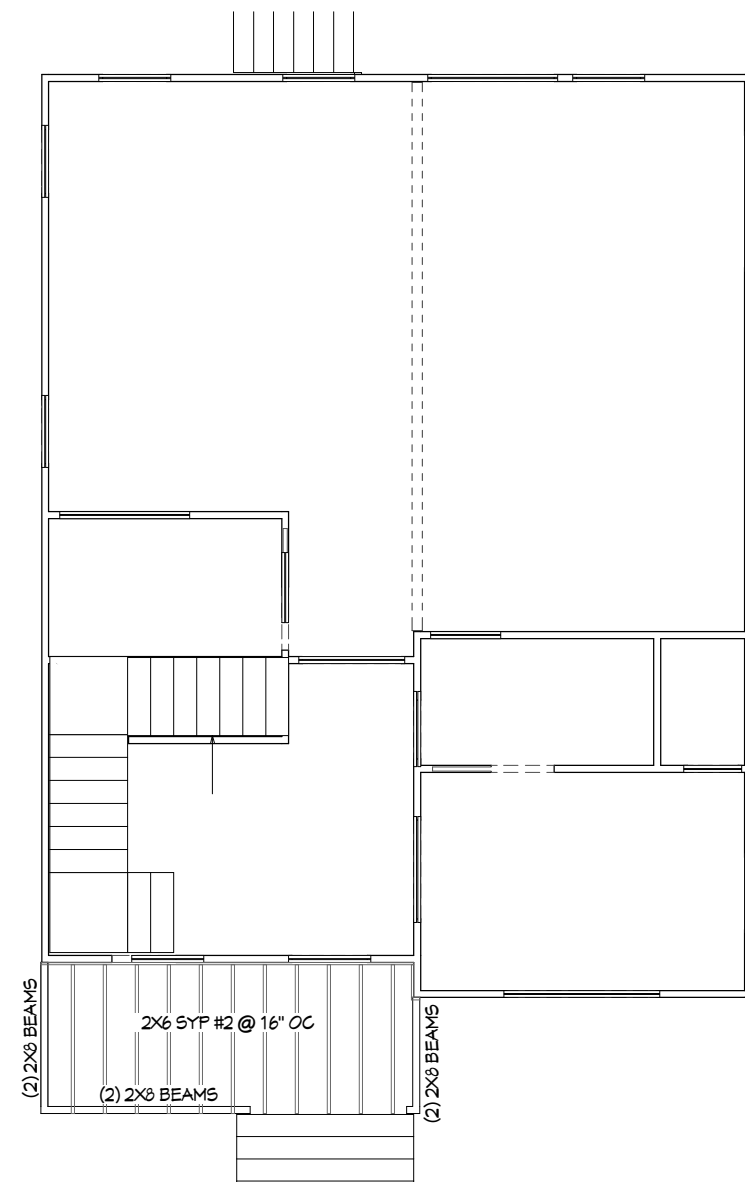

First Floor-Ceiling Framing  
Scale: 1/8" = 1'

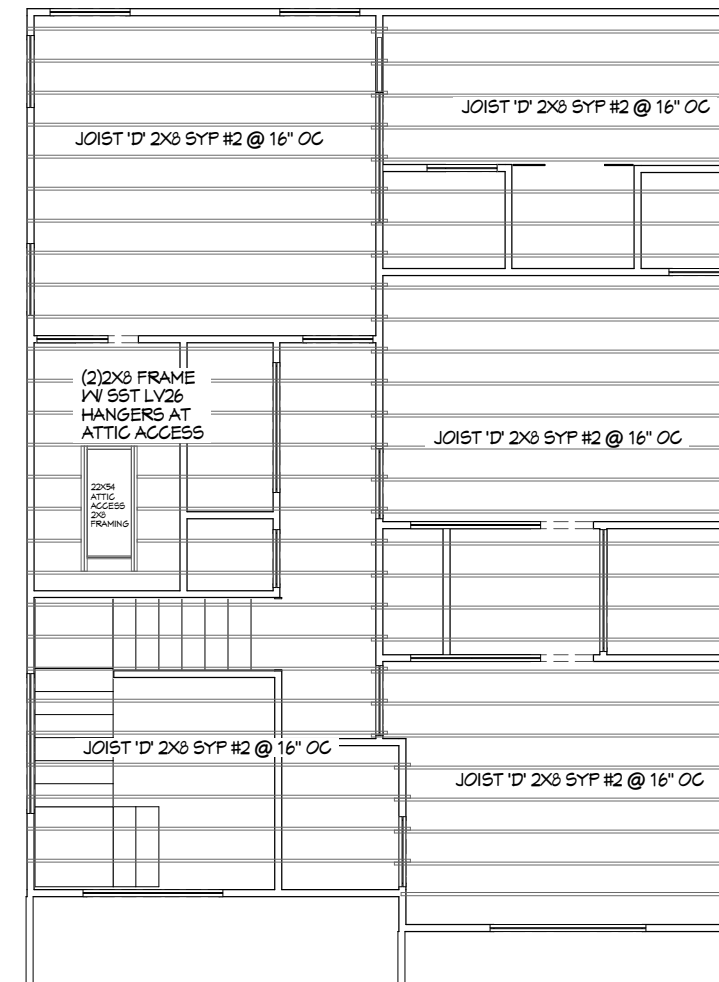

Second Floor-Ceiling Framing  
Scale: 1/8" = 1'

TABLE R602.7(3)  
GIRDER AND HEADER SPANS<sup>a</sup> FOR OPEN PORCHES (Maximum span for Douglas fir-larch, hem-fir, Southern pine and spruce-pine-fir<sup>b</sup>)

SIZE	SUPPORTING ROOF						SUPPORTING FLOOR	
	GROUND SNOW LOAD (psf)							
	30		50		70			
	DEPTH OF PORCH <sup>c</sup> (feet)						8	14
	8	14	8	14	8	14		
2-2 x 6	7-6	5-8	6-2	4-8	5-4	4-0	6-4	4-9
2-2 x 8	10-1	7-7	8-3	6-2	7-1	5-4	8-5	6-4
2-2 x 10	12-4	9-4	10-1	7-7	8-9	6-7	10-4	7-9
2-2 x 12	14-4	10-10	11-8	8-10	10-1	7-8	11-11	9-0

TABLE R802.5.1(2)  
CEILING JOIST SPANS FOR COMMON LUMBER SPECIES (Uninhabitable attics with limited storage, live load = 20 psf, L/Δ = 240)

CEILING JOIST SPACING (inches)	SPECIES AND GRADE	DEAD LOAD = 10 psf				
		2 x 4	2 x 6	2 x 8	2 x 10	
		Maximum ceiling joist spans				
		(feet - inches)				
16"	Southern pine	SS	9-4	14-7	19-3	24-7
	Southern pine	#1	8-11	14-0	17-9	20-9
	Southern pine	#2	8-0	12-0	15-3	18-1
	Southern pine	#3	6-2	9-2	11-6	14-0

NUMBER	DATE	REVISION TABLE	REVISED BY	DESCRIPTION

RELEASED FOR  
CONSTRUCTION

NEW CONSTRUCTION  
103 14th Street  
Cumming, GA 30043



DATE:  
6/13/2023

SCALE:

SHEET:

S1.3

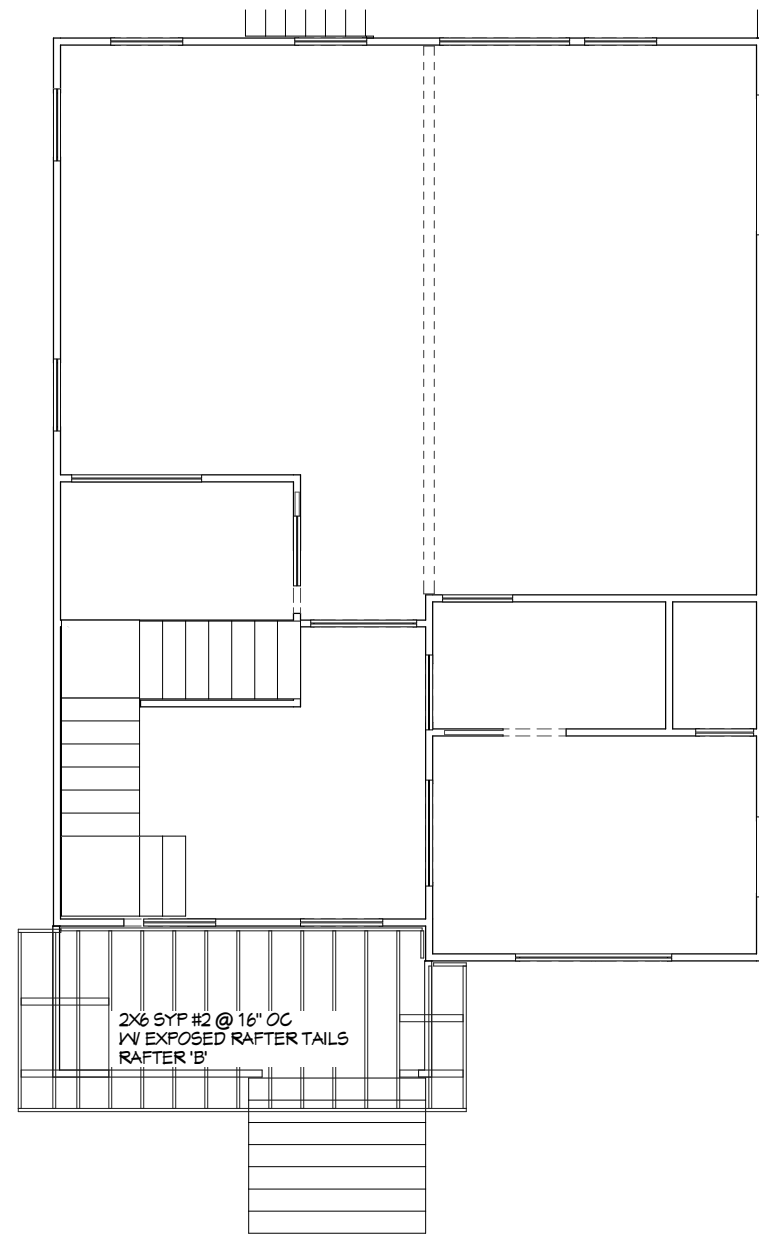

First Floor-Roof Framing  
Scale: 1/8" = 1'

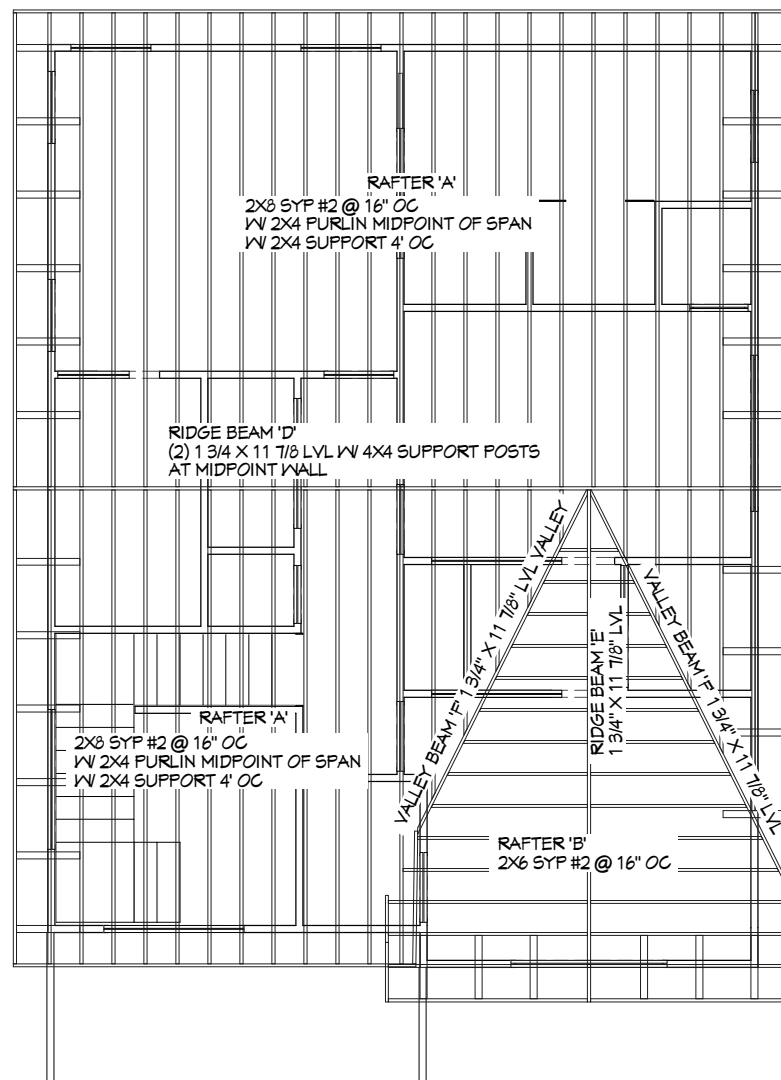

Second Floor-Roof Framing  
Scale: 1/8" = 1'

TABLE R802.4.1(3)  
RAFTER SPANS FOR COMMON LUMBER SPECIES (Ground snow load = 30 psf, ceiling not attached to rafters, L/Δ = 180)

RAFTER SPACING (inches)	SPECIES AND GRADE		DEAD LOAD = 10 psf					DEAD LOAD = 20 psf				
			2 x 4	2 x 6	2 x 8	2 x 10	2 x 12	2 x 4	2 x 6	2 x 8	2 x 10	2 x 12
			Maximum rafter spans <sup>a</sup>									
		(feet - inches)	(feet - inches)	(feet - inches)	(feet - inches)	(feet - inches)	(feet - inches)	(feet - inches)	(feet - inches)	(feet - inches)	(feet - inches)	(feet - inches)
16"	Southern pine	SS	8-11	14-1	18-6	23-8	Note b	8-11	14-1	18-5	1-11	25-11
	Southern pine	#1	8-7	13-0	16-6	19-3	22-10	7-10	11-7	14-9	17-3	20-5
	Southern pine	#2	7-6	11-2	14-2	16-10	19-10	6-8	10-0	12-8	15-1	17-9
	Southern pine	#3	5-9	8-6	10-8	13-0	15-4	5-2	7-7	9-7	11-7	13-9

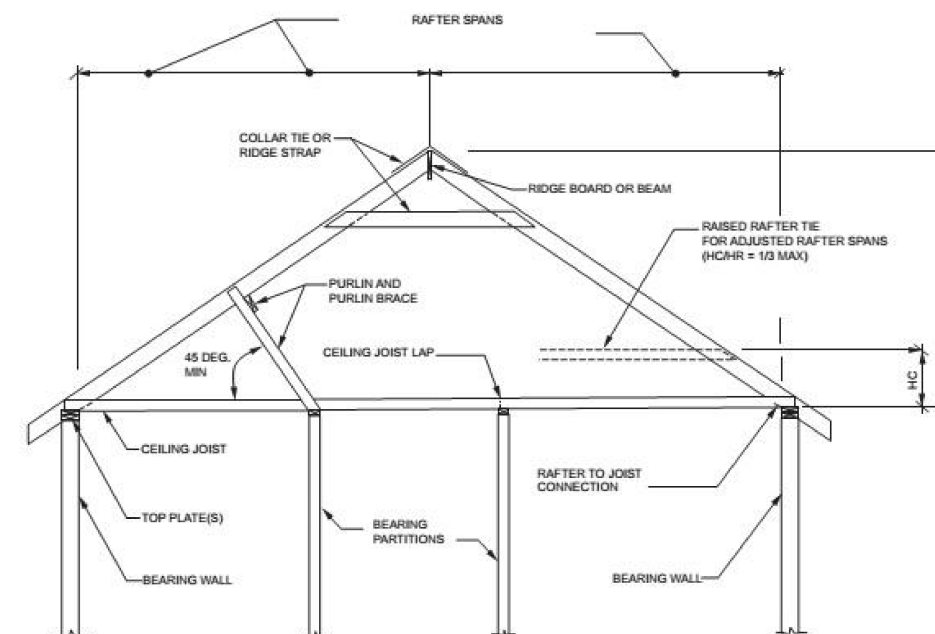

For SI: 1 inch = 25.4 mm, 1 foot = 305 mm, 1 degree = 0.018 rad.

$H_c$  = Height of ceiling joists or rafter ties measured vertically above the top of rafter support walls.  
 $H_r$  = Height of roof ridge measured vertically above the top of the rafter support walls.

FIGURE R802.4.5  
BRACED RAFTER CONSTRUCTION

NUMBER	DATE	REVISION TABLE	REVISED BY	DESCRIPTION

RELEASED FOR  
CONSTRUCTION

NEW CONSTRUCTION  
103 14th Street  
Cumming, GA 30043



DATE:  
6/13/2023

SCALE:

SHEET:

S1.4

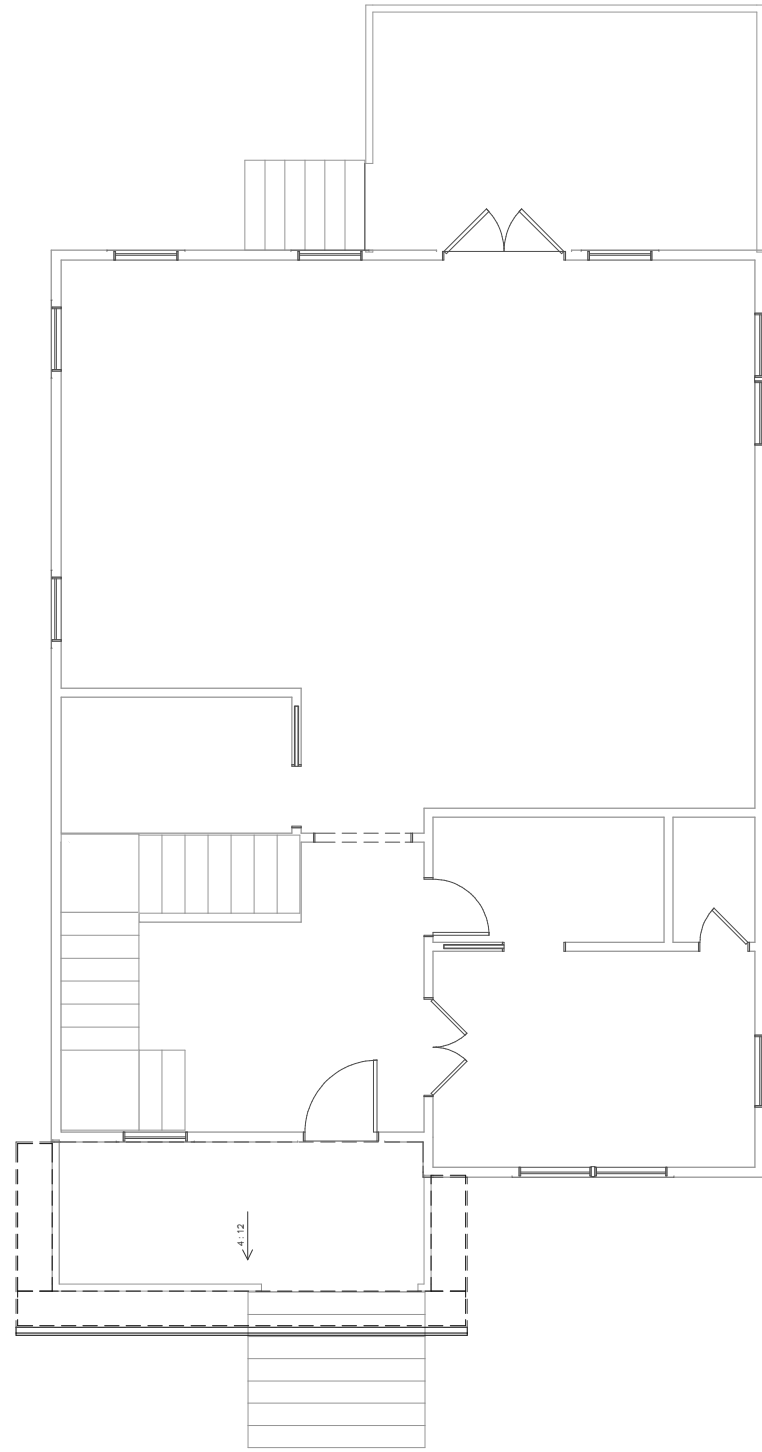

First Floor-Roof Plan  
Scale: 1/8" = 1'

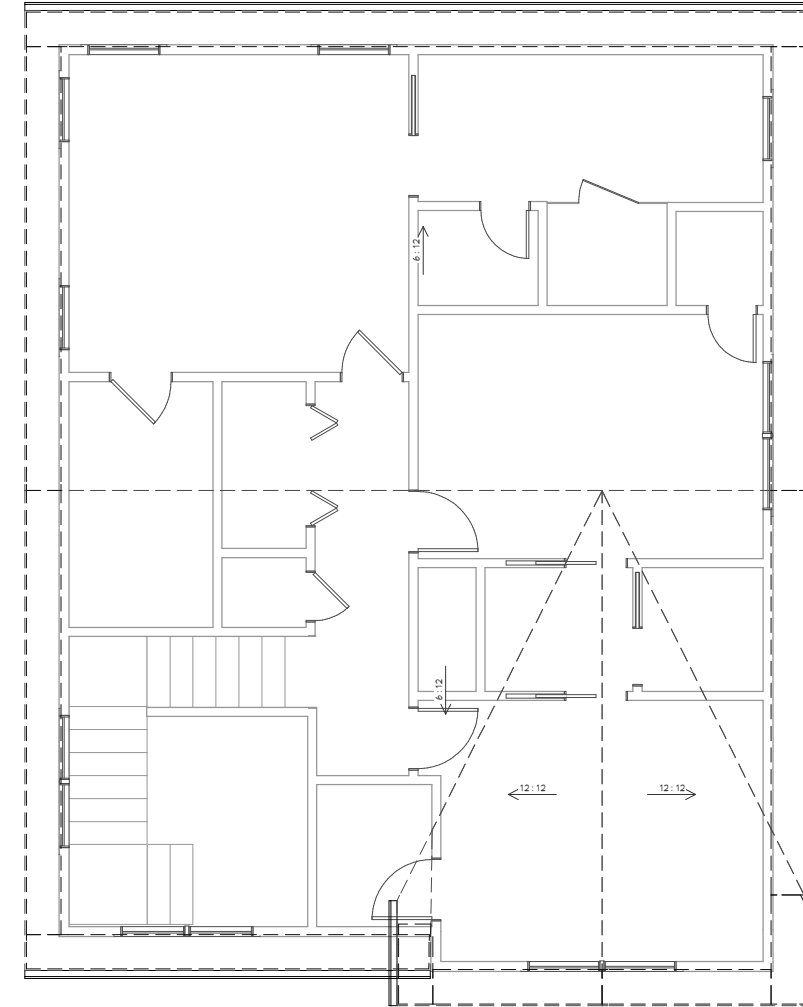

Second Floor-Roof Plan  
Scale: 1/8" = 1'

NUMBER	DATE	REVISION TABLE	REVISED BY	DESCRIPTION

RELEASED FOR  
CONSTRUCTION

NEW CONSTRUCTION  
103 14th Street  
Cumming, GA 30043



DATE:

6/13/2023

SCALE:

SHEET:

S1.5

REVISION TABLE	REVISED BY	DESCRIPTION

RELEASED FOR  
CONSTRUCTION

NEW CONSTRUCTION  
103 14th Street  
Cumming, GA 30043



DATE:

6/13/2023

SCALE:

SHEET:

S1.6

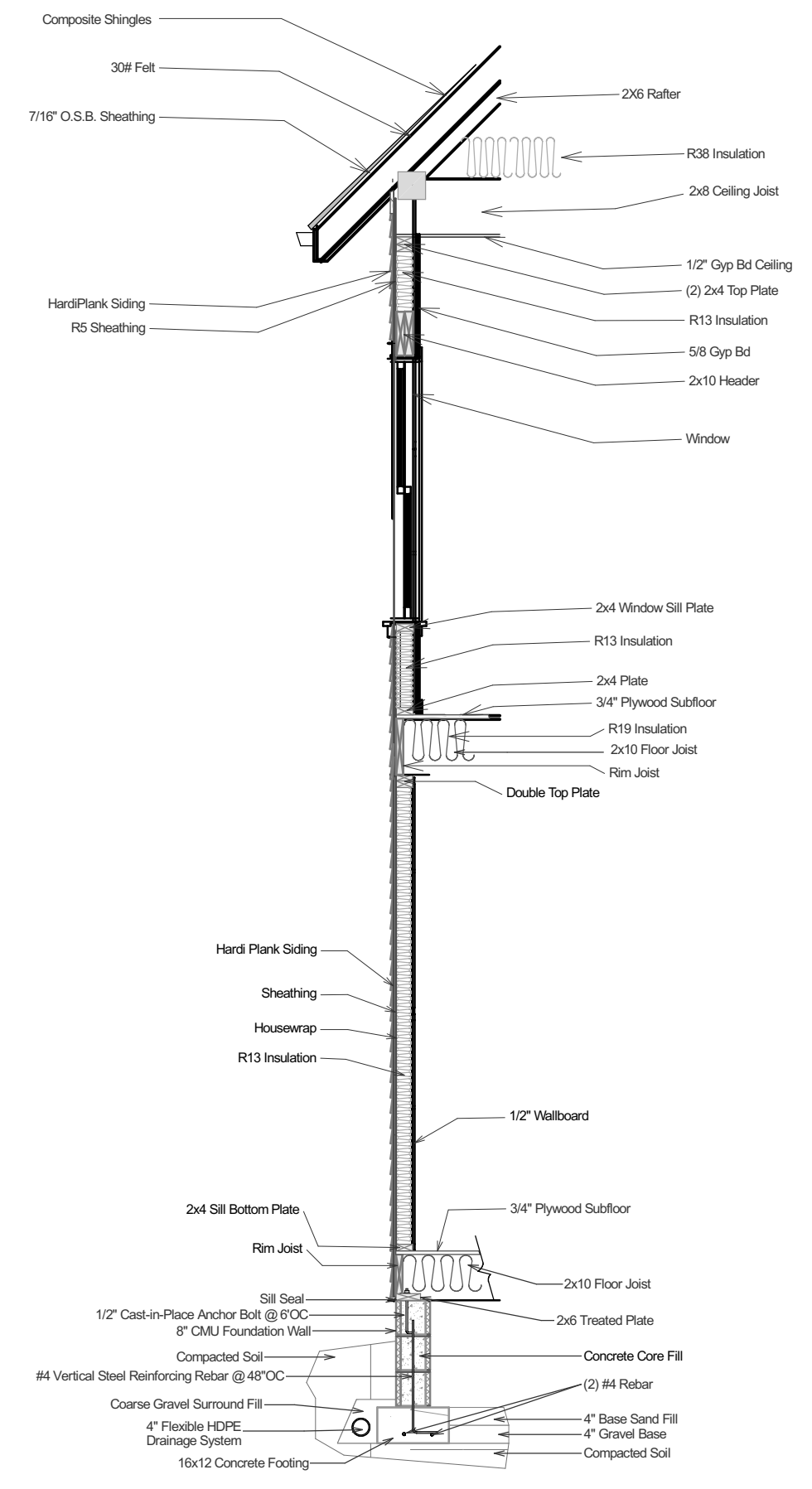

TYP. EXTERIOR WALL  
SCALE: NTS

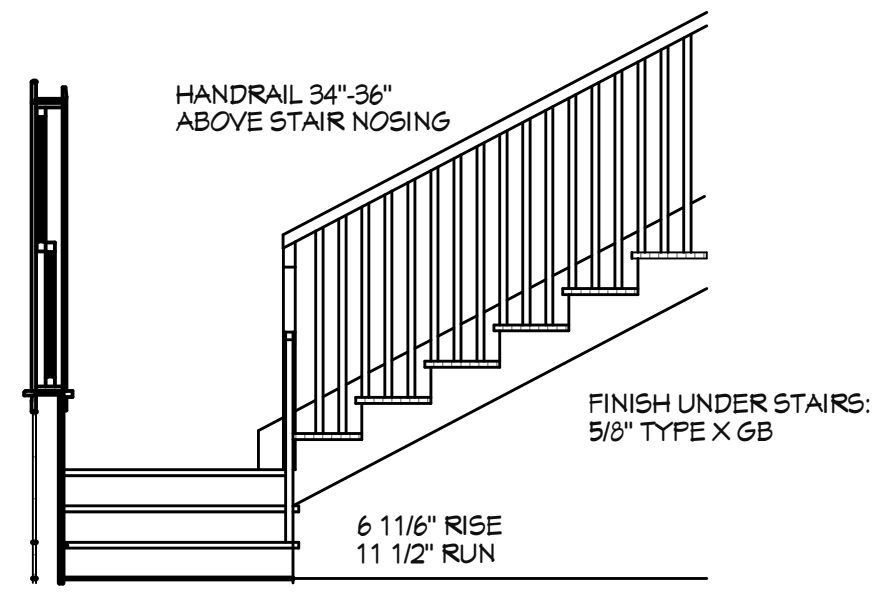

Interior Stair Detail  
Scale: 3/8" = 1'

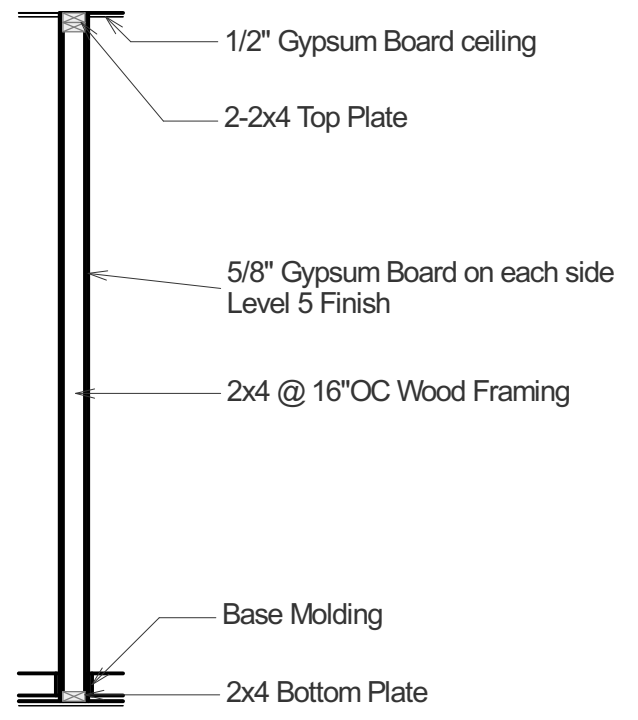

Interior Wall Detail

**Table 5. Fastener Spacing for a Southern Pine, Douglas Fir-Larch, or Hem-Fir Deck Ledger or Band or Rim Joist and a 2-inch Nominal Solid-Sawn Spruce-Pine-Fir Band Joist or LVL Rim Joist.**<sup>3,4,5,6,8</sup>  
(Deck Live Load = 40 psf, Deck Dead Load = 10 psf)

Connection Details	Rim Joist or Band Joist	Joist Span						
		6'-0" and less	6'-1" to 8'-0"	8'-1" to 10'-0"	10'-1" to 12'-0"	12'-1" to 14'-0"	14'-1" to 16'-0"	16'-1" to 18'-0"
<b>On-Center Spacing of Fasteners</b>								
$\frac{1}{2}$ " diameter lag screw <sup>1</sup> with $\frac{15}{32}$ " maximum sheathing	1" LVL	24"	18"	14"	12"	10"	9"	8"
	1- $\frac{1}{8}$ " LVL	28"	21"	16"	14"	12"	10"	9"
	1- $\frac{1}{2}$ " Lumber	30"	23"	18"	15"	13"	11"	10"
$\frac{1}{2}$ " diameter bolt with $\frac{15}{32}$ " maximum sheathing	1" LVL	24"	18"	14"	12"	10"	9"	8"
	1- $\frac{1}{8}$ " LVL	28"	21"	16"	14"	12"	10"	9"
	1- $\frac{1}{2}$ " Lumber	36"	36"	34"	29"	24"	21"	19"
$\frac{1}{2}$ " diameter bolt with $\frac{15}{32}$ " maximum sheathing and $\frac{1}{2}$ " stacked washers <sup>2,7</sup>	1- $\frac{1}{2}$ " Lumber	36"	36"	29"	24"	21"	18"	16"

- The tip of the lag screw shall fully extend beyond the inside face of the band or rim joist.
- The maximum gap between the face of the ledger board and face of the wall sheathing shall be  $\frac{1}{2}$ ".
- Ledgers shall be flashed or caulked to prevent water from contacting the house band joist (see Figures 14 and 15).
- Lag screws and bolts shall be staggered per Figure 19.
- Deck ledgers shall be minimum 2x8 pressure-preservative-treated No.2 grade lumber, or other approved materials as established by standard engineering practice.
- When solid-sawn pressure-preservative-treated deck ledgers are attached to engineered wood products (minimum 1" thick wood structural panel band joist or structural composite lumber including laminated veneer lumber), the ledger attachment shall be designed in accordance with accepted engineering practice. Tabulated values based on 300 lbs and 350 lbs for 1" and 1- $\frac{1}{8}$ " LVL rim joist, respectively.
- Wood structural panel sheathing, gypsum board sheathing, or foam sheathing shall be permitted between the band or rim joist and ledger. Stacked washers are permitted in combination with wood structural panel sheathing, but are not permitted in combination with gypsum board or foam sheathing. The maximum distance between the face of the ledger board and the face of the band joist shall be 1".
- Fastener spacing also applies to Southern Pine, Douglas Fir-Larch, and Hem-Fir band or rim joists.

**Figure 19. Ledger Board Fastener Spacing and Clearances.**

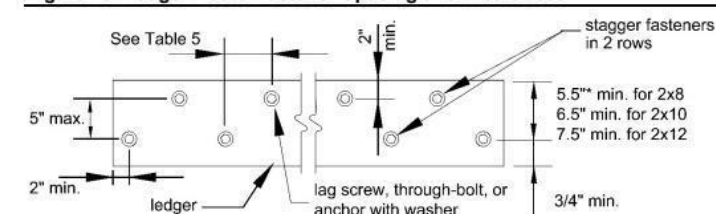

**Figure 14. General Attachment of Ledger Board to Band Joist or Rim Joist.**

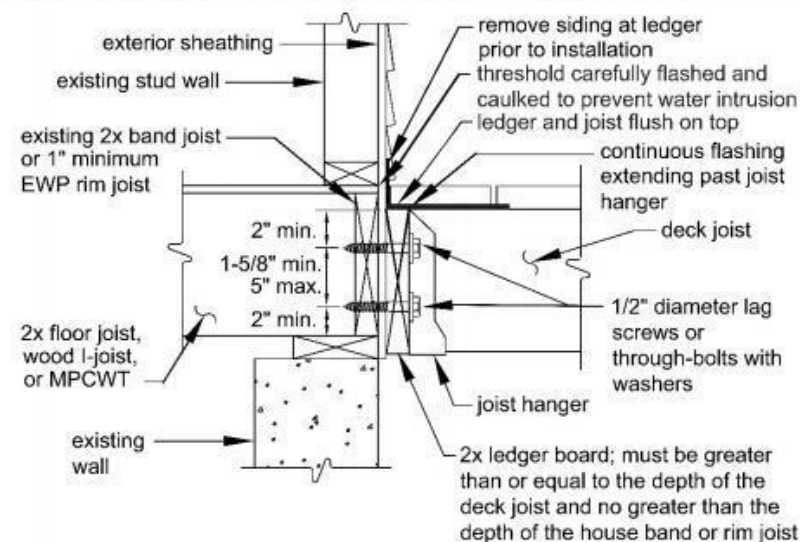

**Figure 15. Attachment of Ledger Board to Foundation Wall (Concrete or Solid Masonry).**

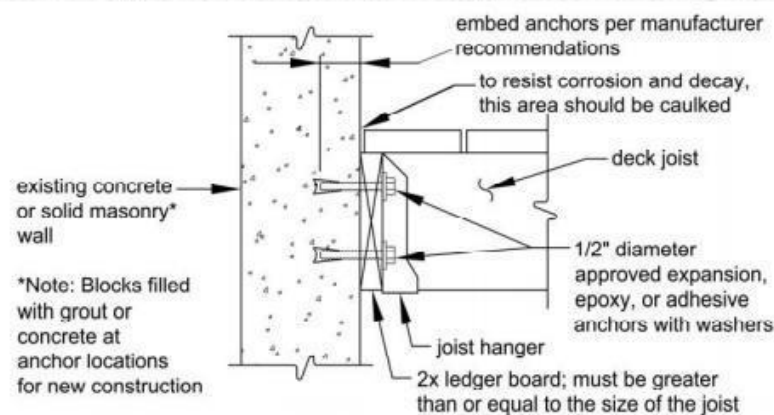
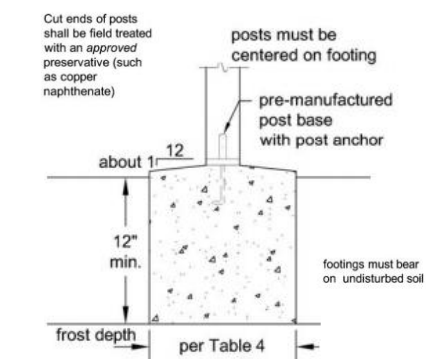

**Table 4. Post Height for 6x6<sup>5</sup> and Footing Sizes for all Posts.**

Beam Span, L <sub>b</sub>	Joist Span L <sub>j</sub>	Post Heights <sup>1</sup>					Footing Sizes <sup>2</sup>		
		Southern Pine	Douglas Fir-Larch <sup>3</sup>	Hem-Fir, Western Cedars	Redwood	Ponderosa Pine, Red Pine, SPP <sup>3</sup>	Round Footing Diameter	Square Footing	Footing Thickness <sup>4</sup>
6'	≤10'	14'	14'	14'	14'	14'	18"	16"x16"	7"
	≤14'	14'	14'	14'	14'	14'	21"	18"x18"	8"
	≤18'	14'	14'	12'	14'	11'	24"	21"x21"	10"
8'	≤10'	14'	14'	14'	14'	14'	20"	18"x18"	8"
	≤14'	14'	14'	14'	14'	11'	24"	21"x21"	10"
	≤18'	14'	13'	11'	12'	8'	27"	24"x24"	11"
10'	≤10'	14'	14'	14'	14'	12'	23"	20"x20"	9"
	≤14'	14'	13'	11'	13'	8'	27"	24"x24"	11"
	≤18'	12'	11'	8'	11'	2'	31"	27"x27"	13"
12'	≤10'	14'	14'	12'	14'	10'	25"	22"x22"	10"
	≤14'	13'	12'	9'	11'	5'	30"	26"x26"	13"
	≤18'	11'	9'	6'	9'	2'	34"	30"x30"	15"
14'	≤10'	14'	13'	11'	13'	8'	27"	24"x24"	11"
	≤14'	11'	10'	7'	10'	2'	32"	29"x29"	14"
	≤18'	9'	8'	2'	8'	NP	37"	33"x33"	16"
16'	≤10'	13'	12'	10'	12'	6'	29"	26"x26"	12"
	≤14'	10'	9'	5'	9'	2'	35"	31"x31"	15"
	≤18'	7'	5'	2'	7'	NP	40"	35"x35"	18"
18'	≤10'	12'	11'	8'	11'	2'	31"	27"x27"	13"
	≤14'	9'	8'	2'	8'	NP	37"	33"x33"	16"
	≤18'	5'	2'	2'	6'	NP	42"	37"x37"	19"

- Assumes 40 psf live load, 10 psf dead load, L<sub>b</sub>/4 and L<sub>j</sub>/4 overhangs, No 2. grade and wet service conditions.
- Assumes 1,500 psf soil bearing capacity and 150 pcf concrete. Value may be multiplied by 0.9 for corner posts.
- Incising assumed for Douglas Fir-Larch, Hem-Fir, and Spruce-Pine-Fir.
- Assumes 2,500 psi compressive strength of concrete. Coordinate footing thickness with post base and anchor requirements.
- 8x8 nominal posts may be substituted anywhere in Table 4 to a maximum height of 14'.

**Figure 12. Typical Footing**



NUMBER	DATE	REVISION TABLE	REVISION BY	DESCRIPTION

RELEASED FOR CONSTRUCTION

NEW CONSTRUCTION  
103 14th Street  
Cumming, GA 30043



DATE:  
6/13/2023

SCALE:

SHEET:

D1

**Table 3A. Dimension Lumber Deck Beam Spans (L<sub>B</sub>)<sup>1</sup> Supporting a Single Span of Joists with or without Overhangs.**

Species	Size <sup>4</sup>	Joist Spans (L) Less Than or Equal to:						
		6'	8'	10'	12'	14'	16'	18'
Southern Pine	2-2x6	6'-8"	5'-8"	5'-1"	4'-7"	4'-3"	4'-0"	3'-9"
	2-2x8	8'-6"	7'-4"	6'-6"	5'-11"	5'-6"	5'-1"	4'-9"
	2-2x10	10'-1"	8'-9"	7'-9"	7'-1"	6'-6"	6'-1"	5'-9"
Southern Pine	2-2x12	11'-11"	10'-4"	9'-2"	8'-4"	7'-9"	7'-3"	6'-9"
	3-2x6	7'-11"	7'-2"	6'-5"	5'-10"	5'-5"	5'-0"	4'-9"
	3-2x8	10'-7"	9'-3"	8'-3"	7'-6"	6'-11"	6'-5"	6'-1"
	3-2x10	12'-9"	11'-0"	9'-9"	8'-9"	8'-3"	7'-8"	7'-3"
	3-2x12	15'-0"	13'-0"	11'-7"	10'-6"	9'-9"	9'-1"	8'-7"

**Table 2. Maximum Joist Spans and Overhangs.<sup>1</sup>**

Species	Size	Joist Spacing (o.c.)					
		12"	16"	24"	12"	16"	24"
		Allowable Span <sup>2</sup> (L <sub>J</sub> )			Allowable Overhang <sup>3</sup> (L <sub>O</sub> )		
Southern Pine	2x6 <sup>5</sup>	9'-11"	9'-0"	7'-7"	1'-0"	1'-1"	1'-3"
	2x8	13'-1"	11'-10"	9'-8"	1'-10"	2'-0"	2'-4"
	2x10	16'-2"	14'-0"	11'-5"	3'-1"	3'-5"	2'-10"
	2x12	18'-0" <sup>7</sup>	16'-6"	13'-6"	4'-6"	4'-2"	3'-4"

**Figure 1A. Joist Span – Joists Attached at House and Bearing Over Beam.**

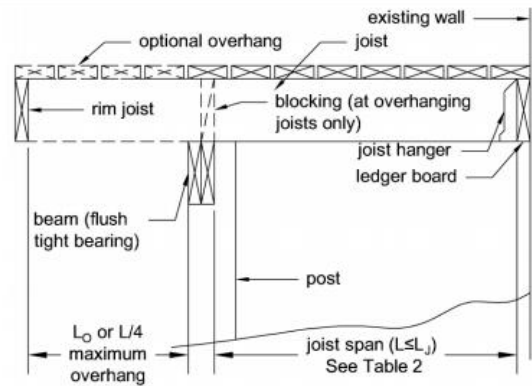

**Figure 6. Joist-to-Beam Detail.**

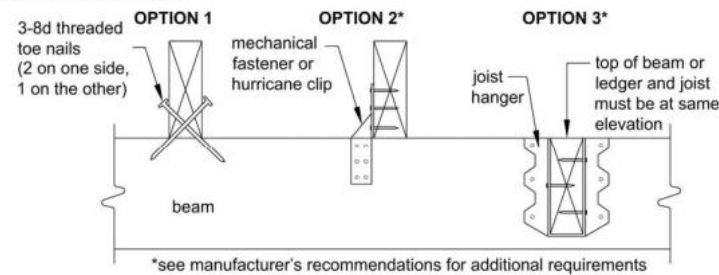

**Table 3A. Joist Hanger Vertical Capacity.**

Joist Size	Minimum Capacity, lbs
2x6	400
2x8	500
2x10	600
2x12	700

**Figure 8A. Post-to-Beam Attachment Requirements.**

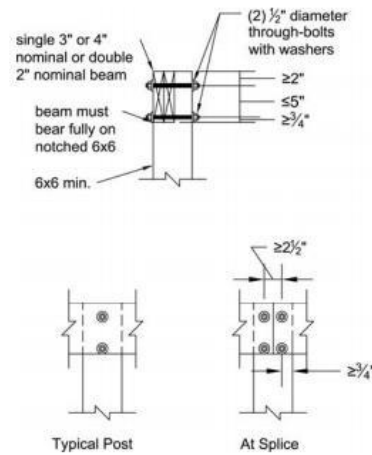

**Figure 10. Diagonal Bracing.**

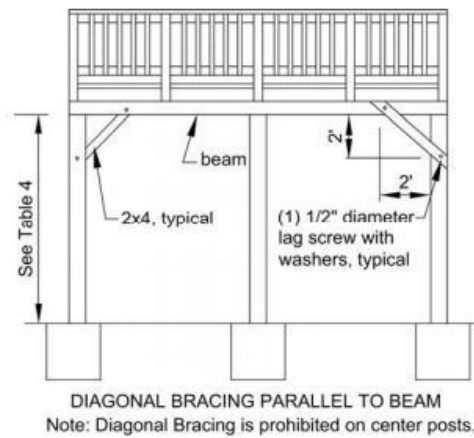

**Figure 24. Example Guard Detail.**

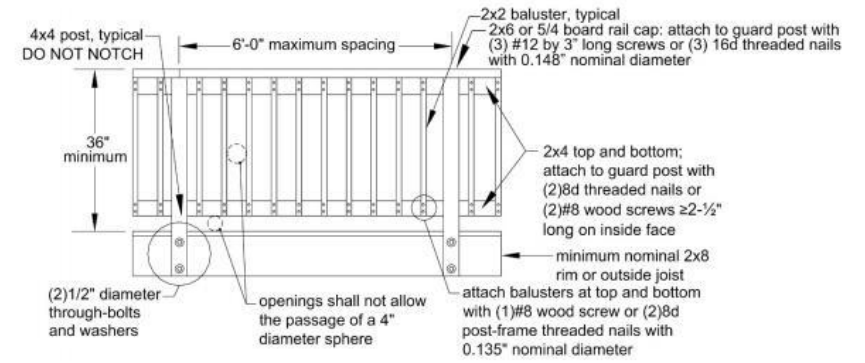

**Figure 26. Guard Post to Rim Joist Example.**

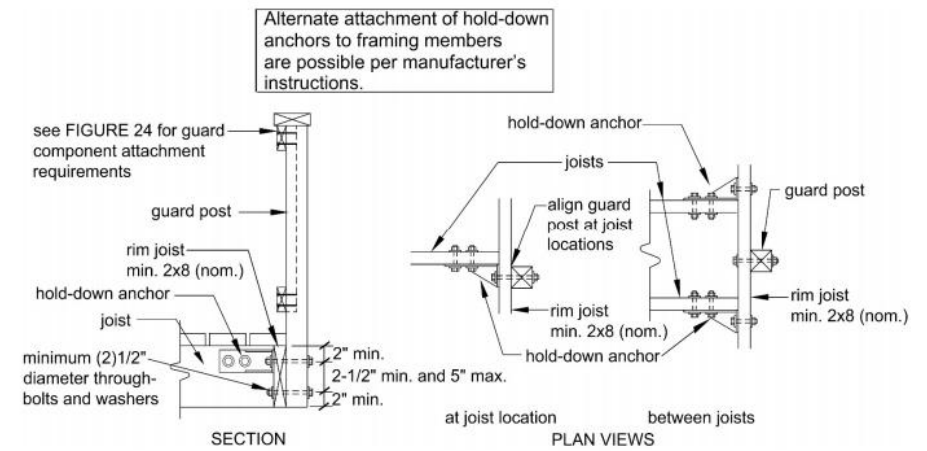

**Figure 25. Guard Post to Outside-Joist Example.**

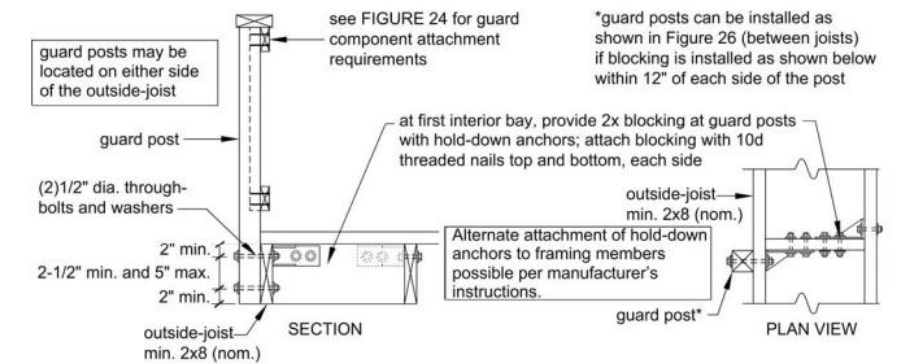

**Figure 34. Stair Footing Detail.**

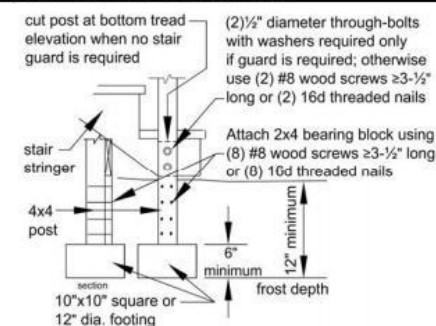

**Figure 27. Tread and Riser Detail.**

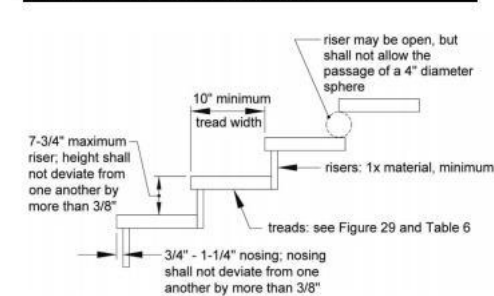

**Figure 30. Stair Guard Requirements.**

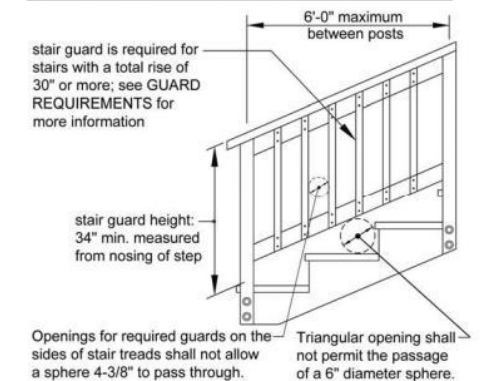

RELEASED FOR CONSTRUCTION

NEW CONSTRUCTION  
103 14th Street  
Cumming, GA 30043



DATE:  
6/13/2023  
SCALE:  
SHEET:  
D2

Proposed First Floor Framing Plan			
Member Name	Results	Current Solution	Comments
Beam "A"	Passed	3 piece(s) 2 x 12 SPF No.1/No.2	
Beam "B"	Passed	2 piece(s) 2 x 10 SPF No.1/No.2	
Joist "A"	Passed	1 piece(s) 2 x 12 SPF No.1/No.2 @ 16" OC	
Joist "B"	Passed	1 piece(s) 2 x 8 SPF No.1/No.2 @ 16" OC	
Proposed Second Floor Framing Plan			
Member Name	Results	Current Solution	Comments
Beam "C"	Passed	4 piece(s) 1 3/4" x 16" 2.0E MicroIam® LVL	
Joist "C"	Passed	1 piece(s) 2 x 12 SPF No.1/No.2 @ 16" OC	
Proposed Second Floor Ceiling Framing Plan			
Member Name	Results	Current Solution	Comments
Joist "D"	Passed	1 piece(s) 2 x 8 SPF No.1/No.2 @ 16" OC	
Proposed Roof Framing Plan			
Member Name	Results	Current Solution	Comments
Ridge Beam "D"	Passed	2 piece(s) 1 3/4" x 11 7/8" 2.0E MicroIam® LVL	
Ridge Beam "E"	Passed	1 piece(s) 1 3/4" x 11 7/8" 2.0E MicroIam® LVL	
Valley Beam "F"	Passed	1 piece(s) 1 3/4" x 11 7/8" 2.0E MicroIam® LVL	
Rafter "A"	Passed	1 piece(s) 2 x 8 SPF No.1/No.2 @ 16" OC	
Rafter "B"	Passed	1 piece(s) 2 x 6 SPF No.1/No.2 @ 16" OC	

Proposed First Floor Framing Plan, Beam "A"  
3 piece(s) 2 x 12 SPF No.1/No.2

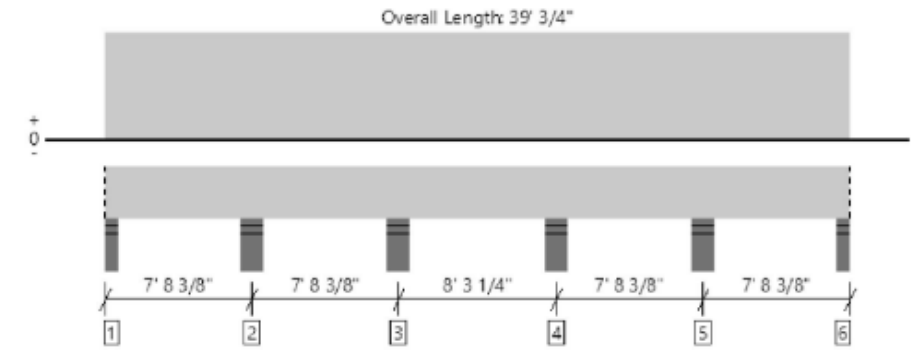

All locations are measured from the outside face of left support (or left cantilever end). All dimensions are horizontal.

Design Results	Actual @ Location	Allowed	Result	LDf	Load: Combination (Pattern)
Member Reaction (lbs)	8223 @ 7' 8 3/8"	11475 (6.00")	Passed (72%)	-	1.0 D + 1.0 L (Adj Spans)
Shear (lbs)	3153 @ 6' 6 1/8"	4556	Passed (69%)	1.00	1.0 D + 1.0 L (Adj Spans)
Moment (Ft-lbs)	-6018 @ 7' 8 3/8"	6921	Passed (87%)	1.00	1.0 D + 1.0 L (Adj Spans)
Live Load Defl. (in)	0.045 @ 3' 9 9/16"	0.188	Passed (L/999+)	-	1.0 D + 1.0 L (Alt Spans)
Total Load Defl. (in)	0.060 @ 3' 8 11/16"	0.377	Passed (L/999+)	-	1.0 D + 1.0 L (Alt Spans)

System : Floor  
Member Type : Flush Beam  
Building Use : Residential  
Building Code : IBC 2018  
Design Methodology : ASD

- Deflection criteria: LL (L/480) and TL (L/240).
- Allowed moment does not reflect the adjustment for the beam stability factor.
- Applicable calculations are based on NDS.

Supports	Bearing Length			Loads to Supports (lbs)			Accessories
	Total	Available	Required	Dead	Floor Live	Factored	
1 - Stud wall - SPF	3.50'	3.50'	1.63'	984	2141/-253	3125	Blocking
2 - Stud wall - SPF	6.00'	6.00'	4.30'	2658	5565	8223	None
3 - Stud wall - SPF	6.00'	6.00'	4.20'	2469	5561	8030	None
4 - Stud wall - SPF	6.00'	6.00'	4.20'	2469	5561	8030	None
5 - Stud wall - SPF	6.00'	6.00'	4.30'	2657	5564	8221	None
6 - Stud wall - SPF	3.50'	3.50'	1.63'	984	2140/-253	3124	Blocking

Blocking Panels are assumed to carry no loads applied directly above them and the full load is applied to the member being designed.

Lateral Bracing	Bracing Intervals	Comments
Top Edge (Lu)	16' 11" o/c	
Bottom Edge (Lu)	11' 1" o/c	

Maximum allowable bracing intervals based on applied load.

Vertical Loads	Location (Side)	Tributary Width	Dead (0.90)	Floor Live (1.00)	Comments
0 - Self Weight (PLF)	0 to 39' 3/4"	N/A	12.8	-	
1 - Uniform (PSF)	0 to 39' 3/4" (Front)	15'	20.0	40.0	Default Load

**Weyerhaeuser Notes**

Weyerhaeuser warrants that the sizing of its products will be in accordance with Weyerhaeuser product design criteria and published design values. Weyerhaeuser expressly disclaims any other warranties related to the software. Use of this software is not intended to circumvent the need for a design professional as determined by the authority having jurisdiction. The designer of record, builder or framer is responsible to assure that this calculation is compatible with the overall project. Accessories (Rim Board, Blocking Panels and Squash Blocks) are not designed by this software. Products manufactured at Weyerhaeuser facilities are third-party certified to sustainable forestry standards. Weyerhaeuser Engineered Lumber Products have been evaluated by ICC-ES under evaluation reports ESR-1153 and ESR-1387 and/or tested in accordance with applicable ASTM standards. For current code evaluation reports, Weyerhaeuser product literature and installation details refer to [www.weyerhaeuser.com/woodproducts/documentlibrary](http://www.weyerhaeuser.com/woodproducts/documentlibrary).

The product application, input design loads, dimensions and support information have been provided by ForteWEB Software Operator

REVISION TABLE	REVISION BY	DESCRIPTION
NUMBER	DATE	

RELEASED FOR CONSTRUCTION

NEW CONSTRUCTION  
103 14th Street  
Cumming, GA 30043



DATE:

6/13/2023

SCALE:

SHEET:

S1.7

Proposed First Floor Framing Plan, Beam "B"  
2 piece(s) 2 x 10 SPF No.1/No.2

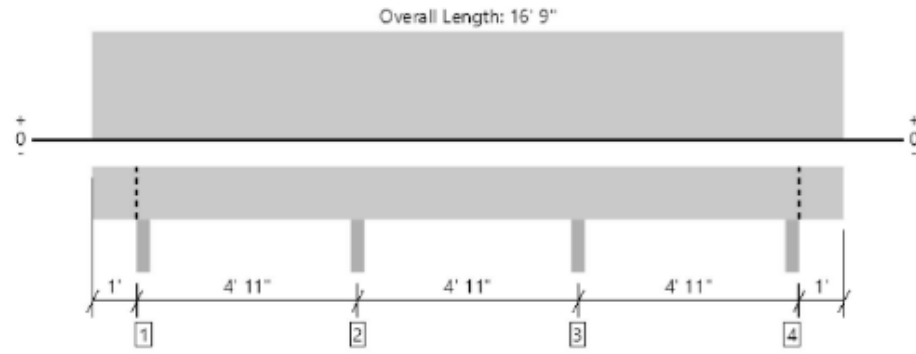

All locations are measured from the outside face of left support (or left cantilever end). All dimensions are horizontal.

Design Results	Actual @ Location	Allowed	Result	LDF	Load: Combination (Pattern)
Member Reaction (lbs)	1723 @ 5' 11"	4463 (3,50")	Passed (39%)	—	1.0 D + 1.0 L (Adj Spans)
Shear (lbs)	602 @ 5'	2498	Passed (24%)	1.00	1.0 D + 1.0 L (Adj Spans)
Moment (Ft-lbs)	-790 @ 10' 10"	3431	Passed (23%)	1.00	1.0 D + 1.0 L (Adj Spans)
Live Load Defl. (in)	0.006 @ 13' 3 7/16"	0.119	Passed (L/999+)	—	1.0 D + 1.0 L (All Spans)
Total Load Defl. (in)	0.008 @ 3' 5 5/16"	0.239	Passed (L/999+)	—	1.0 D + 1.0 L (All Spans)

- Deflection criteria: LL (L/480) and TL (L/240).
- Overhang deflection criteria: LL (2L/480) and TL (2L/240).
- Allowed moment does not reflect the adjustment for the beam stability factor.
- Applicable calculations are based on NDS.

System : Floor  
Member Type : Flush Beam  
Building Use : Residential  
Building Code : IBC 2018  
Design Methodology : ASD

Supports	Bearing Length			Loads to Supports (lbs)			Accessories
	Total	Available	Required	Dead	Floor Live	Factored	
1 - Column - SPF	3,50"	3,50"	1,50"	343	694	1037	Blocking
2 - Column - SPF	3,50"	3,50"	1,50"	553	1170	1723	None
3 - Column - SPF	3,50"	3,50"	1,50"	553	1170	1723	None
4 - Column - SPF	3,50"	3,50"	1,50"	343	694	1037	Blocking

• Blocking Panels are assumed to carry no loads applied directly above them and the full load is applied to the member being designed.

Lateral Bracing	Bracing Intervals	Comments
Top Edge (Lu)	16' 9" o/c	
Bottom Edge (Lu)	16' 9" o/c	

• Maximum allowable bracing intervals based on applied load.

Vertical Loads	Location (Side)	Tributary Width	Dead (0,90)	Floor Live (1,00)	Comments
0 - Self Weight (PLF)	0 to 16' 9"	N/A	7,0	—	
1 - Uniform (PSF)	0 to 16' 9" (Front)	5'	20,0	40,0	Default Load

**Weyerhaeuser Notes**

Weyerhaeuser warrants that the sizing of its products will be in accordance with Weyerhaeuser product design criteria and published design values. Weyerhaeuser expressly disclaims any other warranties related to the software. Use of this software is not intended to circumvent the need for a design professional as determined by the authority having jurisdiction. The designer of record, builder or framer is responsible to assure that this calculation is compatible with the overall project. Accessories (Rim Board, Blocking Panels and Squash Blocks) are not designed by this software. Products manufactured at Weyerhaeuser facilities are third-party certified to sustainable forestry standards. Weyerhaeuser Engineered Lumber Products have been evaluated by ICC-ES under evaluation reports ESR-1153 and ESR-1387 and/or tested in accordance with applicable ASTM standards. For current code evaluation reports, Weyerhaeuser product literature and installation details refer to www.weyerhaeuser.com/woodproducts/document-library.

The product application, input design loads, dimensions and support information have been provided by ForteWEB Software Operator

Proposed First Floor Framing Plan, Joist "A"  
1 piece(s) 2 x 12 SPF No.1/No.2 @ 16" OC

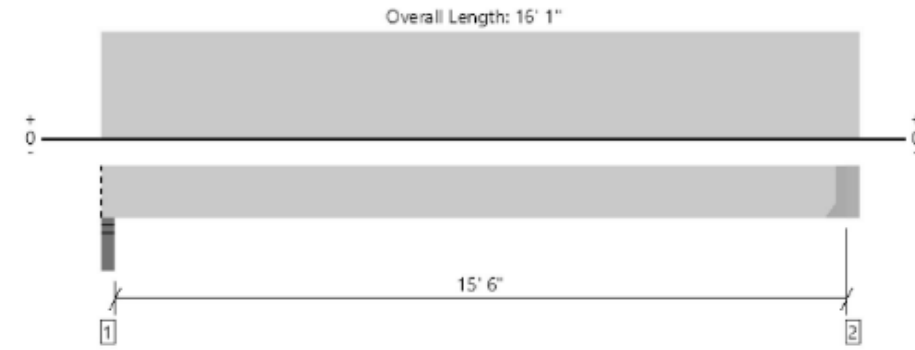

All locations are measured from the outside face of left support (or left cantilever end). All dimensions are horizontal.

Design Results	Actual @ Location	Allowed	Result	LDF	Load: Combination (Pattern)
Member Reaction (lbs)	623 @ 15' 9 1/2"	956 (1,50")	Passed (65%)	—	1.0 D + 1.0 L (All Spans)
Shear (lbs)	548 @ 14' 10 1/4"	1519	Passed (36%)	1.00	1.0 D + 1.0 L (All Spans)
Moment (Ft-lbs)	2428 @ 8'	2653	Passed (92%)	1.00	1.0 D + 1.0 L (All Spans)
Live Load Defl. (in)	0.284 @ 8'	0.390	Passed (L/658)	—	1.0 D + 1.0 L (All Spans)
Total Load Defl. (in)	0.426 @ 8'	0.779	Passed (L/439)	—	1.0 D + 1.0 L (All Spans)
TJ-Pro™ Rating	N/A	N/A	N/A	—	N/A

- Deflection criteria: LL (L/480) and TL (L/240).
- Allowed moment does not reflect the adjustment for the beam stability factor.
- A 15% increase in the moment capacity has been added to account for repetitive member usage.
- Applicable calculations are based on NDS.
- No composite action between deck and joist was considered in analysis.

System : Floor  
Member Type : Joist  
Building Use : Residential  
Building Code : IBC 2018  
Design Methodology : ASD

Supports	Bearing Length			Loads to Supports (lbs)			Accessories
	Total	Available	Required	Dead	Floor Live	Factored	
1 - Stud wall - SPF	3,50"	3,50"	1,50"	213	427	640	Blocking
2 - Hanger on 11 1/4" SPF beam	3,50"	Hanger <sup>1</sup>	1,50"	216	431	647	See note <sup>1</sup>

- Blocking Panels are assumed to carry no loads applied directly above them and the full load is applied to the member being designed.
- At hanger supports, the Total Bearing dimension is equal to the width of the material that is supporting the hanger
- <sup>1</sup> See Connector grid below for additional information and/or requirements.

Lateral Bracing	Bracing Intervals	Comments
Top Edge (Lu)	3' 6" o/c	
Bottom Edge (Lu)	15' 10" o/c	

• Maximum allowable bracing intervals based on applied load.

**Connector: Simpson Strong-Tie**

Support	Model	Seat Length	Top Fasteners	Face Fasteners	Member Fasteners	Accessories
2 - Face Mount Hanger	LUS28	1.75"	N/A	6-10dx1.5	3-10d	

• Refer to manufacturer notes and instructions for proper installation and use of all connectors.

Vertical Load	Location (Side)	Spacing	Dead (0,90)	Floor Live (1,00)	Comments
1 - Uniform (PSF)	0 to 16' 1"	16"	20,0	40,0	Default Load

**Weyerhaeuser Notes**

Weyerhaeuser warrants that the sizing of its products will be in accordance with Weyerhaeuser product design criteria and published design values. Weyerhaeuser expressly disclaims any other warranties related to the software. Use of this software is not intended to circumvent the need for a design professional as determined by the authority having jurisdiction. The designer of record, builder or framer is responsible to assure that this calculation is compatible with the overall project. Accessories (Rim Board, Blocking Panels and Squash Blocks) are not designed by this software. Products manufactured at Weyerhaeuser facilities are third-party certified to sustainable forestry standards. Weyerhaeuser Engineered Lumber Products have been evaluated by ICC-ES under evaluation reports ESR-1153 and ESR-1387 and/or tested in accordance with applicable ASTM standards. For current code evaluation reports, Weyerhaeuser product literature and installation details refer to www.weyerhaeuser.com/woodproducts/document-library.

REVISION TABLE	NUMBER	DATE	REVISED BY	DESCRIPTION

RELEASED FOR CONSTRUCTION

NEW CONSTRUCTION  
103 14th Street  
Cumming, GA 30043



DATE:

6/13/2023

SCALE:

SHEET:

S1.8

Proposed First Floor Framing Plan, Joist "B"  
1 piece(s) 2 x 8 SPF No.1/No.2 @ 16" OC

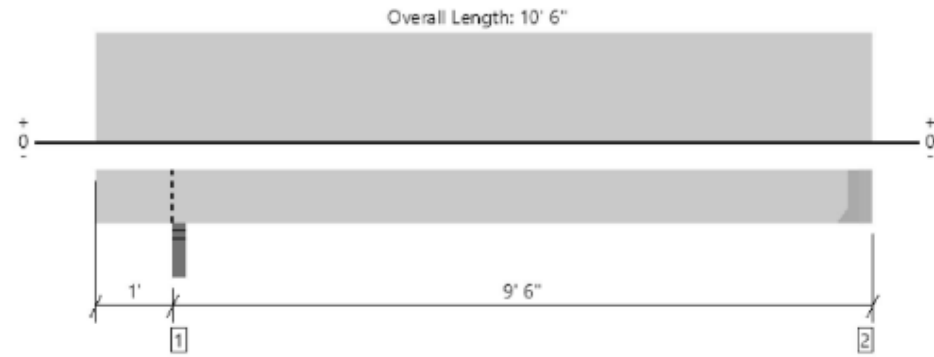

All locations are measured from the outside face of left support (or left cantilever end). All dimensions are horizontal.

Design Results	Actual @ Location	Allowed	Result	LDF	Load: Combination (Pattern)
Member Reaction (lbs)	361 @ 10' 2 1/2"	956 (1,50")	Passed (38%)	-	1.0 D + 1.0 L (All Spans)
Shear (lbs)	312 @ 9' 7 1/4"	979	Passed (32%)	1.00	1.0 D + 1.0 L (All Spans)
Moment (Ft-lbs)	813 @ 5' 8 7/16"	1322	Passed (61%)	1.00	1.0 D + 1.0 L (All Spans)
Live Load Defl. (in)	0.121 @ 5' 8 1/8"	0.227	Passed (L/896)	-	1.0 D + 1.0 L (All Spans)
Total Load Defl. (in)	0.180 @ 5' 8 1/4"	0.453	Passed (L/605)	-	1.0 D + 1.0 L (All Spans)
TJ-Pro™ Rating	N/A	N/A	N/A	-	N/A

System : Floor  
Member Type : Joist  
Building Use : Residential  
Building Code : IBC 2018  
Design Methodology : ASD

- Deflection criteria: LL (L/480) and TL (L/240).
- Overhang deflection criteria: LL (2L/480) and TL (2L/240).
- Allowed moment does not reflect the adjustment for the beam stability factor.
- A 15% increase in the moment capacity has been added to account for repetitive member usage.
- Applicable calculations are based on NDS.
- No composite action between deck and joist was considered in analysis.

Supports	Bearing Length			Loads to Supports (lbs)			Accessories
	Total	Available	Required	Dead	Floor Live	Factored	
1 - Stud wall - SPF	3.50"	3.50"	1.50"	153	307	460	Blocking
2 - Hanger on 7 1/4" SPF beam	3.50"	Hanger <sup>1</sup>	1.50"	127	257	384	See note <sup>1</sup>

- Blocking Panels are assumed to carry no loads applied directly above them and the full load is applied to the member being designed.
- At hanger supports, the Total Bearing dimension is equal to the width of the material that is supporting the hanger
- <sup>1</sup> See Connector grid below for additional information and/or requirements.

Lateral Bracing	Bracing Intervals	Comments
Top Edge (Lu)	10' 3" o/c	
Bottom Edge (Lu)	10' 3" o/c	

• Maximum allowable bracing intervals based on applied load.

**Connector: Simpson Strong-Tie**

Support	Model	Seat Length	Top Fasteners	Face Fasteners	Member Fasteners	Accessories
2 - Face Mount Hanger	LJ26	1.50"	N/A	6-10dx1.5	4-10dx1.5	

- Refer to manufacturer notes and instructions for proper installation and use of all connectors.

Vertical Load	Location (Side)	Spacing	Dead (0.90)	Floor Live (1.00)	Comments
1 - Uniform (PSF)	0 to 10' 6"	16"	20.0	40.0	Default Load

**Weyerhaeuser Notes**

Proposed Second Floor Framing Plan, Beam "C"  
4 piece(s) 1 3/4" x 16" 2,0E MicroIam® LVL

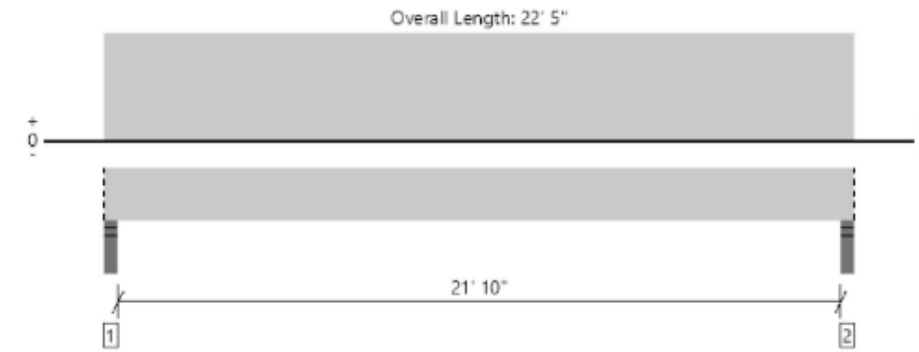

All locations are measured from the outside face of left support (or left cantilever end). All dimensions are horizontal.

Design Results	Actual @ Location	Allowed	Result	LDF	Load: Combination (Pattern)
Member Reaction (lbs)	10286 @ 2"	10413 (3,50")	Passed (99%)	-	1.0 D + 1.0 L (All Spans)
Shear (lbs)	8794 @ 1' 7 1/2"	21280	Passed (41%)	1.00	1.0 D + 1.0 L (All Spans)
Moment (Ft-lbs)	55940 @ 11' 2 1/2"	62228	Passed (90%)	1.00	1.0 D + 1.0 L (All Spans)
Live Load Defl. (in)	0.698 @ 11' 2 1/2"	0.736	Passed (L/380)	-	1.0 D + 1.0 L (All Spans)
Total Load Defl. (in)	1.085 @ 11' 2 1/2"	1.104	Passed (L/244)	-	1.0 D + 1.0 L (All Spans)

System : Floor  
Member Type : Flush Beam  
Building Use : Residential  
Building Code : IBC 2018  
Design Methodology : ASD

- Deflection criteria: LL (L/360) and TL (L/240).
- Allowed moment does not reflect the adjustment for the beam stability factor.
- Member should be side-loaded from both sides of the member or braced to prevent rotation.

Supports	Bearing Length			Loads to Supports (lbs)			Accessories
	Total	Available	Required	Dead	Floor Live	Factored	
1 - Stud wall - SPF	3.50"	3.50"	3.46"	3673	6613	10286	Blocking
2 - Stud wall - SPF	3.50"	3.50"	3.46"	3673	6613	10286	Blocking

- Blocking Panels are assumed to carry no loads applied directly above them and the full load is applied to the member being designed.

Lateral Bracing	Bracing Intervals	Comments
Top Edge (Lu)	7' 1" o/c	
Bottom Edge (Lu)	22' 5" o/c	

• Maximum allowable bracing intervals based on applied load.

Vertical Loads	Location (Side)	Tributary Width	Dead (0.90)	Floor Live (1.00)	Comments
0 - Self Weight (PLF)	0 to 22' 5"	N/A	32.7	-	
1 - Uniform (PSF)	0 to 22' 5" (Front)	14' 9"	20.0	40.0	Default Load

**Weyerhaeuser Notes**

Weyerhaeuser warrants that the sizing of its products will be in accordance with Weyerhaeuser product design criteria and published design values. Weyerhaeuser expressly disclaims any other warranties related to the software. Use of this software is not intended to circumvent the need for a design professional as determined by the authority having jurisdiction. The designer of record, builder or framer is responsible to assure that this calculation is compatible with the overall project. Accessories (Rim Board, Blocking Panels and Squash Blocks) are not designed by this software. Products manufactured at Weyerhaeuser facilities are third-party certified to sustainable forestry standards. Weyerhaeuser Engineered Lumber Products have been evaluated by ICC-ES under evaluation reports ESR-1153 and ESR-1387 and/or tested in accordance with applicable ASTM standards. For current code evaluation reports, Weyerhaeuser product literature and installation details refer to [www.weyerhaeuser.com/woodproducts/documentlibrary](http://www.weyerhaeuser.com/woodproducts/documentlibrary).

The product application, input design loads, dimensions and support information have been provided by ForteWEB Software Operator

REVISION TABLE	NUMBER	DATE	REVISED BY	DESCRIPTION

RELEASED FOR CONSTRUCTION

NEW CONSTRUCTION  
103 14th Street  
Cumming, GA 30043



DATE:

6/13/2023

SCALE:

SHEET:

S1.9

Proposed Second Floor Framing Plan, Joist "C"  
**1 piece(s) 2 x 12 SPF No.1/No.2 @ 16" OC**

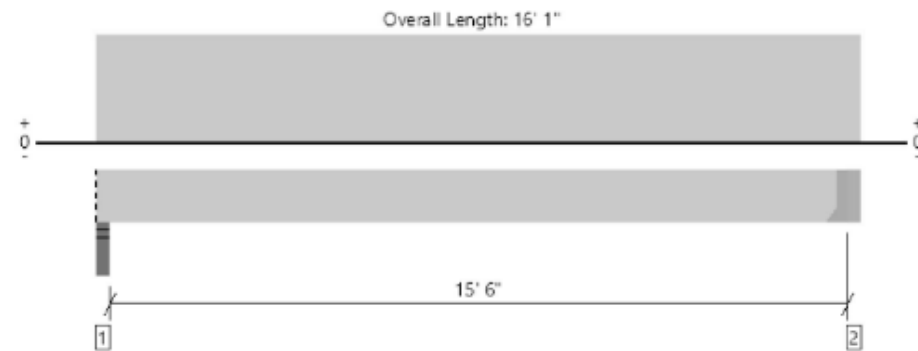

All locations are measured from the outside face of left support (or left cantilever end). All dimensions are horizontal.

Design Results	Actual @ Location	Allowed	Result	LDF	Load: Combination (Pattern)
Member Reaction (lbs)	623 @ 15' 9 1/2"	956 (1,50")	Passed (65%)	-	1.0 D + 1.0 L (All Spans)
Shear (lbs)	548 @ 14' 10 1/4"	1519	Passed (36%)	1.00	1.0 D + 1.0 L (All Spans)
Moment (Ft-lbs)	2428 @ 8'	2653	Passed (92%)	1.00	1.0 D + 1.0 L (All Spans)
Live Load Defl. (in)	0.284 @ 8'	0.390	Passed (L/658)	-	1.0 D + 1.0 L (All Spans)
Total Load Defl. (in)	0.426 @ 8'	0.779	Passed (L/439)	-	1.0 D + 1.0 L (All Spans)
TJ-Pro™ Rating	N/A	N/A	N/A	-	N/A

System : Floor  
 Member Type : Joist  
 Building Use : Residential  
 Building Code : IBC 2018  
 Design Methodology : ASD

- Deflection criteria: LL (L/480) and TL (L/240).
- Allowed moment does not reflect the adjustment for the beam stability factor.
- A 15% increase in the moment capacity has been added to account for repetitive member usage.
- Applicable calculations are based on NDS.
- No composite action between deck and joist was considered in analysis.

Supports	Bearing Length			Loads to Supports (lbs)			Accessories
	Total	Available	Required	Dead	Floor Live	Factored	
1 - Stud wall - SPF	3,50"	3,50"	1,50"	213	427	640	Blocking
2 - Hanger on 11 1/4" LVL beam	3,50"	Hanger <sup>1</sup>	1,50"	216	431	647	See note <sup>1</sup>

- Blocking Panels are assumed to carry no loads applied directly above them and the full load is applied to the member being designed.
- At hanger supports, the Total Bearing dimension is equal to the width of the material that is supporting the hanger
- <sup>1</sup> See Connector grid below for additional information and/or requirements.

Lateral Bracing	Bracing Intervals	Comments
Top Edge (Lu)	3' 6" o/c	
Bottom Edge (Lu)	15' 10" o/c	

• Maximum allowable bracing intervals based on applied load.

Connector: Simpson Strong-Tie						
Support	Model	Seat Length	Top Fasteners	Face Fasteners	Member Fasteners	Accessories
2 - Face Mount Hanger	LUS28	1.75"	N/A	6-10dx1.5	3-10d	

- Refer to manufacturer notes and instructions for proper installation and use of all connectors.

Vertical Load	Location (Side)	Spacing	Dead (0,90)	Floor Live (1,00)	Comments
1 - Uniform (PSF)	0 to 16' 1"	16"	20,0	40,0	Default Load

**Weyerhaeuser Notes**  
 Weyerhaeuser warrants that the sizing of its products will be in accordance with Weyerhaeuser product design criteria and published design values. Weyerhaeuser expressly disclaims any other warranties related to the software. Use of this software is not intended to circumvent the need for a design professional as determined by the authority having jurisdiction. The designer of record, builder or framer is responsible to assure that this calculation is compatible with the overall project. Accessories (Rim Board, Blocking Panels and Squash Blocks) are not designed by this software. Products manufactured at Weyerhaeuser facilities are third-party certified to sustainable forestry standards. Weyerhaeuser Engineered Lumber Products have been evaluated by ICC-ES under evaluation reports ESR-1153 and ESR-1387 and/or tested in accordance with applicable ASTM standards. For current code evaluation reports, Weyerhaeuser product literature and installation details refer to [www.weyerhaeuser.com/woodproducts/document-library](http://www.weyerhaeuser.com/woodproducts/document-library).

Proposed Second Floor Ceiling Framing Plan, Joist "D"  
**1 piece(s) 2 x 8 SPF No.1/No.2 @ 16" OC**

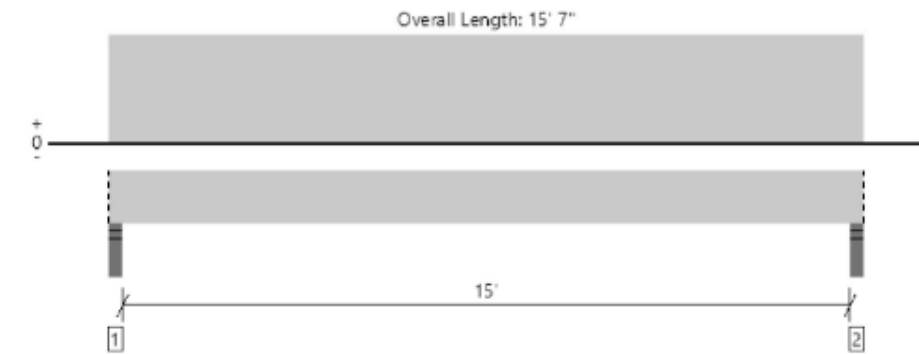

All locations are measured from the outside face of left support (or left cantilever end). All dimensions are horizontal.

Design Results	Actual @ Location	Allowed	Result	LDF	Load: Combination (Pattern)
Member Reaction (lbs)	312 @ 2 1/2"	2231 (3,50")	Passed (14%)	-	1.0 D + 1.0 Lr (All Spans)
Shear (lbs)	276 @ 10 3/4"	1223	Passed (23%)	1.25	1.0 D + 1.0 Lr (All Spans)
Moment (Ft-lbs)	1150 @ 7' 9 1/2"	1653	Passed (70%)	1.25	1.0 D + 1.0 Lr (All Spans)
Live Load Defl. (in)	0.476 @ 7' 9 1/2"	0.758	Passed (L/382)	-	1.0 D + 1.0 Lr (All Spans)
Total Load Defl. (in)	0.714 @ 7' 9 1/2"	1.011	Passed (L/255)	-	1.0 D + 1.0 Lr (All Spans)

System : Roof  
 Member Type : Joist  
 Building Use : Residential  
 Building Code : IBC 2018  
 Design Methodology : ASD  
 Member Pitch : 0/12

- Deflection criteria: LL (L/240) and TL (L/180).
- Allowed moment does not reflect the adjustment for the beam stability factor.
- A 15% increase in the moment capacity has been added to account for repetitive member usage.
- Applicable calculations are based on NDS.

Supports	Bearing Length			Loads to Supports (lbs)			Accessories
	Total	Available	Required	Dead	Roof Live	Factored	
1 - Stud wall - SPF	3,50"	3,50"	1,50"	104	208	312	Blocking
2 - Stud wall - SPF	3,50"	3,50"	1,50"	104	208	312	Blocking

- Blocking Panels are assumed to carry no loads applied directly above them and the full load is applied to the member being designed.

Lateral Bracing	Bracing Intervals	Comments
Top Edge (Lu)	7' 2" o/c	
Bottom Edge (Lu)	15' 7" o/c	

• Maximum allowable bracing intervals based on applied load.

Vertical Load	Location (Side)	Spacing	Dead (0,90)	Roof Live (non-snow: 1,25)	Comments
1 - Uniform (PSF)	0 to 15' 7"	16"	10,0	20,0	Default Load

**Weyerhaeuser Notes**  
 Weyerhaeuser warrants that the sizing of its products will be in accordance with Weyerhaeuser product design criteria and published design values. Weyerhaeuser expressly disclaims any other warranties related to the software. Use of this software is not intended to circumvent the need for a design professional as determined by the authority having jurisdiction. The designer of record, builder or framer is responsible to assure that this calculation is compatible with the overall project. Accessories (Rim Board, Blocking Panels and Squash Blocks) are not designed by this software. Products manufactured at Weyerhaeuser facilities are third-party certified to sustainable forestry standards. Weyerhaeuser Engineered Lumber Products have been evaluated by ICC-ES under evaluation reports ESR-1153 and ESR-1387 and/or tested in accordance with applicable ASTM standards. For current code evaluation reports, Weyerhaeuser product literature and installation details refer to [www.weyerhaeuser.com/woodproducts/document-library](http://www.weyerhaeuser.com/woodproducts/document-library).  
 The product application, input design loads, dimensions and support information have been provided by ForteWEB Software Operator

NUMBER	DATE	REVISION TABLE	REVISION BY	DESCRIPTION

RELEASED FOR  
 CONSTRUCTION

NEW CONSTRUCTION  
 103 14th Street  
 Cumming, GA 30043



DATE:  
 6/13/2023

SCALE:

SHEET:  
 S1.10

Proposed Roof Framing Plan, Ridge Beam "D"  
**2 piece(s) 1 3/4" x 11 7/8" 2.0E Microllam® LVL**

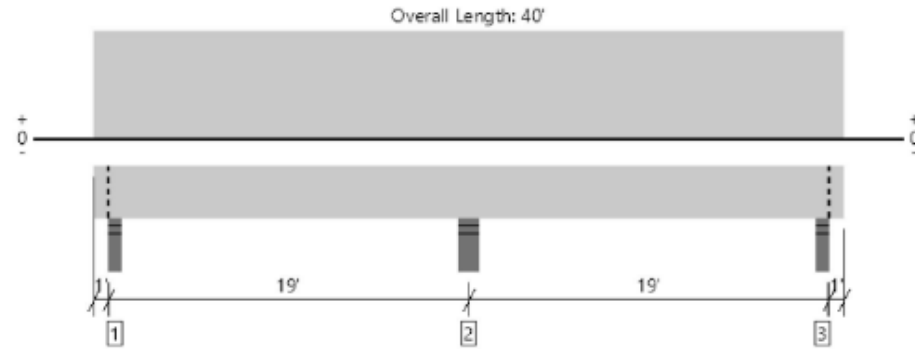

All locations are measured from the outside face of left support (or left cantilever end). All dimensions are horizontal.

Design Results	Actual @ Location	Allowed	Result	LDF	Load: Combination (Pattern)
Member Reaction (lbs)	7334 @ 20'	7809 (5.25")	Passed (94%)	-	1.0 D + 1.0 Lr (Adj Spans)
Shear (lbs)	3290 @ 21' 2 1/2"	9871	Passed (33%)	1.25	1.0 D + 1.0 Lr (Adj Spans)
Moment (ft-lbs)	-13800 @ 20'	22310	Passed (62%)	1.25	1.0 D + 1.0 Lr (Adj Spans)
Live Load Defl. (in)	0.348 @ 30' 3 7/8"	0.943	Passed (L/650)	-	1.0 D + 1.0 Lr (All Spans)
Total Load Defl. (in)	0.495 @ 30' 5 15/16"	1.257	Passed (L/457)	-	1.0 D + 1.0 Lr (All Spans)

System : Roof  
 Member Type : Flush Beam  
 Building Use : Residential  
 Building Code : IBC 2018  
 Design Methodology : ASD  
 Member Pitch : 0/12

- Deflection criteria: LL (L/240) and TL (L/180).
- Overhang deflection criteria: LL (2L/240) and TL (2L/180).
- Allowed moment does not reflect the adjustment for the beam stability factor.

Supports	Bearing Length			Loads to Supports (lbs)			Accessories
	Total	Available	Required	Dead	Roof Live	Factored	
1 - Stud wall - SPF	3.50"	3.50"	1.81"	927	1772	2699	Blocking
2 - Stud wall - SPF	5.25"	5.25"	4.93"	2631	4703	7334	None
3 - Stud wall - SPF	3.50"	3.50"	1.81"	927	1772	2699	Blocking

• Blocking Panels are assumed to carry no loads applied directly above them and the full load is applied to the member being designed.

Lateral Bracing	Bracing Intervals	Comments
Top Edge (Lu)	17' 6" o/c	
Bottom Edge (Lu)	9' 11" o/c	

• Maximum allowable bracing intervals based on applied load.

Vertical Loads	Location (Side)	Tributary Width	Dead (0.90)	Roof Live (non-snow: 1.25)	Comments
0 - Self Weight (PLF)	0 to 40'	N/A	12.1	-	
1 - Uniform (PSF)	0 to 40' (Front)	10'	10.0	20.0	Default Load

**Weyerhaeuser Notes**

Weyerhaeuser warrants that the sizing of its products will be in accordance with Weyerhaeuser product design criteria and published design values. Weyerhaeuser expressly disclaims any other warranties related to the software. Use of this software is not intended to circumvent the need for a design professional as determined by the authority having jurisdiction. The designer of record, builder or framer is responsible to assure that this calculation is compatible with the overall project. Accessories (Rim Board, Blocking Panels and Squash Blocks) are not designed by this software. Products manufactured at Weyerhaeuser facilities are third-party certified to sustainable forestry standards. Weyerhaeuser Engineered Lumber Products have been evaluated by ICC-ES under evaluation reports ESR-1153 and ESR-1387 and/or tested in accordance with applicable ASTM standards. For current code evaluation reports, Weyerhaeuser product literature and installation details refer to [www.weyerhaeuser.com/woodproducts/document-library](http://www.weyerhaeuser.com/woodproducts/document-library).

The product application, input design loads, dimensions and support information have been provided by ForteWEB Software Operator

Proposed Roof Framing Plan, Ridge Beam "E"  
**1 piece(s) 1 3/4" x 11 7/8" 2.0E Microllam® LVL**

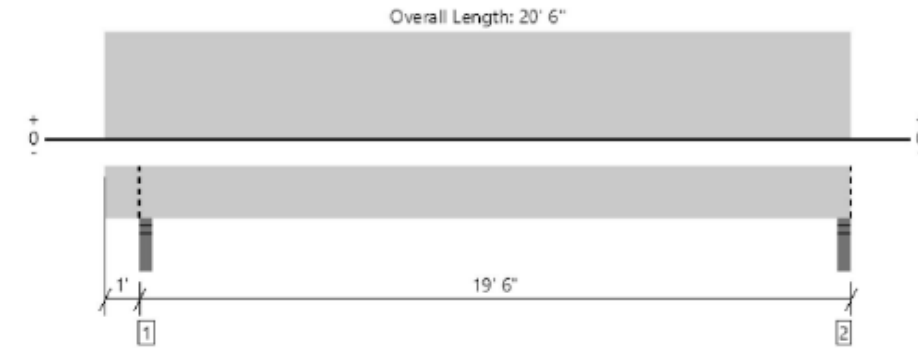

All locations are measured from the outside face of left support (or left cantilever end). All dimensions are horizontal.

Design Results	Actual @ Location	Allowed	Result	LDF	Load: Combination (Pattern)
Member Reaction (lbs)	1681 @ 1' 1 3/4"	2603 (3.50")	Passed (65%)	-	1.0 D + 1.0 Lr (All Spans)
Shear (lbs)	1325 @ 2' 3 3/8"	4936	Passed (27%)	1.25	1.0 D + 1.0 Lr (All Spans)
Moment (ft-lbs)	7147 @ 10' 9 1/8"	11155	Passed (64%)	1.25	1.0 D + 1.0 Lr (All Spans)
Live Load Defl. (in)	0.647 @ 10' 8 15/16"	0.959	Passed (L/356)	-	1.0 D + 1.0 Lr (All Spans)
Total Load Defl. (in)	1.009 @ 10' 8 15/16"	1.279	Passed (L/228)	-	1.0 D + 1.0 Lr (All Spans)

System : Roof  
 Member Type : Flush Beam  
 Building Use : Residential  
 Building Code : IBC 2018  
 Design Methodology : ASD  
 Member Pitch : 0/12

- Deflection criteria: LL (L/240) and TL (L/180).
- Overhang deflection criteria: LL (2L/240) and TL (2L/180).
- Allowed moment does not reflect the adjustment for the beam stability factor.

Supports	Bearing Length			Loads to Supports (lbs)			Accessories
	Total	Available	Required	Dead	Roof Live	Factored	
1 - Stud wall - SPF	3.50"	3.50"	2.26"	604	1077	1681	Blocking
2 - Stud wall - SPF	3.50"	3.50"	2.04"	545	974	1520	Blocking

• Blocking Panels are assumed to carry no loads applied directly above them and the full load is applied to the member being designed.

Lateral Bracing	Bracing Intervals	Comments
Top Edge (Lu)	5' 7" o/c	
Bottom Edge (Lu)	20' 6" o/c	

• Maximum allowable bracing intervals based on applied load.

Vertical Loads	Location (Side)	Tributary Width	Dead (0.90)	Roof Live (non-snow: 1.25)	Comments
0 - Self Weight (PLF)	0 to 20' 6"	N/A	6.1	-	
1 - Uniform (PSF)	0 to 20' 6" (Front)	5'	10.0	20.0	Default Load

**Weyerhaeuser Notes**

Weyerhaeuser warrants that the sizing of its products will be in accordance with Weyerhaeuser product design criteria and published design values. Weyerhaeuser expressly disclaims any other warranties related to the software. Use of this software is not intended to circumvent the need for a design professional as determined by the authority having jurisdiction. The designer of record, builder or framer is responsible to assure that this calculation is compatible with the overall project. Accessories (Rim Board, Blocking Panels and Squash Blocks) are not designed by this software. Products manufactured at Weyerhaeuser facilities are third-party certified to sustainable forestry standards. Weyerhaeuser Engineered Lumber Products have been evaluated by ICC-ES under evaluation reports ESR-1153 and ESR-1387 and/or tested in accordance with applicable ASTM standards. For current code evaluation reports, Weyerhaeuser product literature and installation details refer to [www.weyerhaeuser.com/woodproducts/document-library](http://www.weyerhaeuser.com/woodproducts/document-library).

The product application, input design loads, dimensions and support information have been provided by ForteWEB Software Operator

NUMBER	DATE	REVISION TABLE	REVISED BY	DESCRIPTION

RELEASED FOR CONSTRUCTION

NEW CONSTRUCTION  
 103 14th Street  
 Cumming, GA 30043



DATE:  
6/13/2023

SCALE:

SHEET:

S1.11

Proposed Roof Framing Plan, Valley Beam "F"  
**1 piece(s) 1 3/4" x 11 7/8" 2.0E MicroLam® LVL**

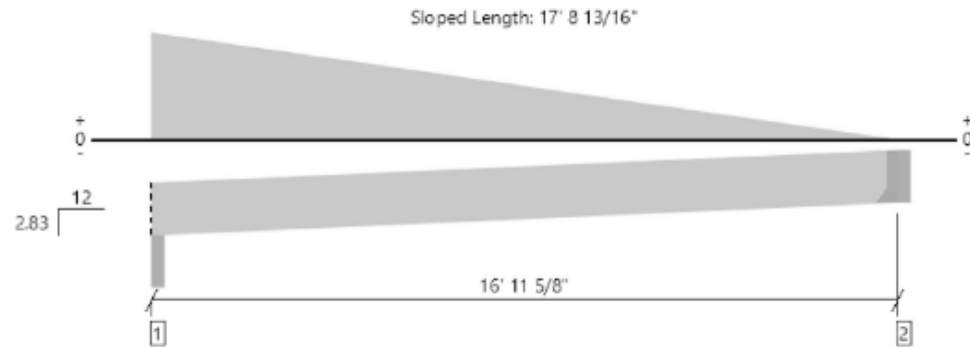

All locations are measured from the outside face of left support (or left cantilever end). All dimensions are horizontal.

Member Length : 17' 8 1/16"

Design Results	Actual @ Location	Allowed	Result	LDF	Load: Combination (Pattern)
Member Reaction (lbs)	1534 @ 2"	2603 (3,50")	Passed (59%)	—	1.0 D + 1.0 Lr (All Spans)
Shear (lbs)	1213 @ 1' 3 1/16"	4936	Passed (25%)	1.25	1.0 D + 1.0 Lr (All Spans)
Moment (Ft-lbs)	4863 @ 7' 3 7/8"	11155	Passed (44%)	1.25	1.0 D + 1.0 Lr (All Spans)
Live Load Defl. (in)	0.343 @ 8' 3"	0.863	Passed (L/604)	—	1.0 D + 1.0 Lr (All Spans)
Total Load Defl. (in)	0.549 @ 8' 3 1/8"	1.151	Passed (L/377)	—	1.0 D + 1.0 Lr (All Spans)

- Deflection criteria: LL (L/240) and TL (L/180).
- Allowed moment does not reflect the adjustment for the beam stability factor.

Supports	Bearing Length			Loads to Supports (lbs)			Accessories
	Total	Available	Required	Dead	Roof Live	Factored	
1 - Beveled Plate - SPF	3,50"	3,50"	2,06"	564	969	1534	Blocking
2 - Hanger on 11 7/8" SPF beam	3,50"	Hanger <sup>1</sup>	1,50"	300	471	771	See note <sup>1</sup>

- Blocking Panels are assumed to carry no loads applied directly above them and the full load is applied to the member being designed.
- At hanger supports, the Total Bearing dimension is equal to the width of the material that is supporting the hanger
- <sup>1</sup> See Connector grid below for additional information and/or requirements.

Lateral Bracing	Bracing Intervals	Comments
Top Edge (Lu)	9' 1" o/c	
Bottom Edge (Lu)	17' 5" o/c	

•Maximum allowable bracing intervals based on applied load.

**Connector: Simpson Strong-Tie**

Support	Model	Seat Length	Top Fasteners	Face Fasteners	Member Fasteners	Accessories
2 - Face Mount Hanger	LSSR1.81Z	1.88"	N/A	14-10dx2.5	12-10dx1.5	

- Refer to manufacturer notes and instructions for proper installation and use of all connectors.

Vertical Loads	Location (Side)	Tributary Width	Dead (0,90)	Roof Live (non-snow: 1,25)	Comments
0 - Self Weight (PLF)	0 to 16' 11 5/8"	N/A	6.1	—	
1 - Tapered (PLF)	0 to 16' 11 5/8"	N/A	87.1 to 0,0	169.7 to 0,0	Generated from Roof Geometry

**Weyerhaeuser Notes**

Weyerhaeuser warrants that the sizing of its products will be in accordance with Weyerhaeuser product design criteria and published design values. Weyerhaeuser expressly disclaims any other warranties related to the software. Use of this software is not intended to circumvent the need for a design professional as determined by the authority having jurisdiction. The designer of record, builder or framer is responsible to assure that this calculation is compatible with the overall project. Accessories (Rim Board, Blocking Panels and Squash Blocks) are not designed by this software. Products manufactured at Weyerhaeuser facilities are third-party certified to sustainable forestry standards. Weyerhaeuser Engineered Lumber Products have been evaluated by ICC-ES under evaluation reports ESR-1153 and ESR-1387

Proposed Roof Framing Plan, Rafter "A"  
**1 piece(s) 2 x 8 SPF No.1/No.2 @ 16" OC**

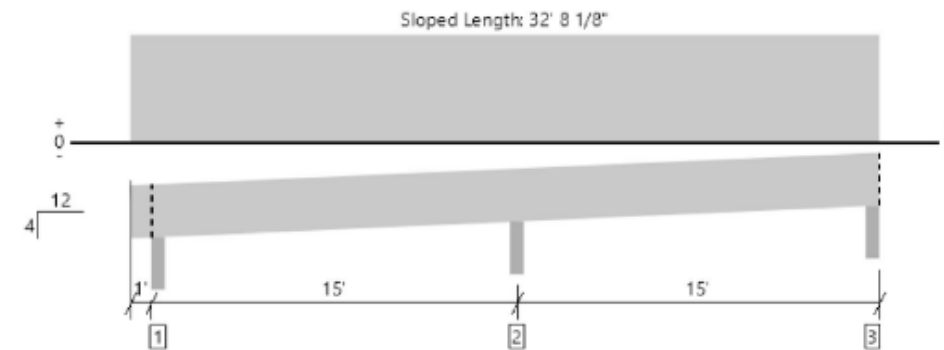

All locations are measured from the outside face of left support (or left cantilever end). All dimensions are horizontal.

Member Length : 32' 10 9/16"

Design Results	Actual @ Location	Allowed	Result	LDF	Load: Combination (Pattern)
Member Reaction (lbs)	753 @ 16"	2352 (3,50")	Passed (32%)	—	1.0 D + 1.0 Lr (Adj Spans)
Shear (lbs)	347 @ 16' 8 5/8"	1223	Passed (28%)	1.25	1.0 D + 1.0 Lr (Adj Spans)
Moment (Ft-lbs)	-1114 @ 16"	1653	Passed (67%)	1.25	1.0 D + 1.0 Lr (Adj Spans)
Live Load Defl. (in)	0.268 @ 24' 1 1/4"	0.780	Passed (L/698)	—	1.0 D + 1.0 Lr (All Spans)
Total Load Defl. (in)	0.373 @ 24' 2 15/16"	1.039	Passed (L/502)	—	1.0 D + 1.0 Lr (All Spans)

- Deflection criteria: LL (L/240) and TL (L/180).
- Overhang deflection criteria: LL (2L/240) and TL (2L/180).
- Allowed moment does not reflect the adjustment for the beam stability factor.
- A 15% increase in the moment capacity has been added to account for repetitive member usage.
- Applicable calculations are based on NDS.

Supports	Bearing Length			Loads to Supports (lbs)			Accessories
	Total	Available	Required	Dead	Roof Live	Factored	
1 - Beveled Plate - SPF	3,50"	3,50"	1,50"	95	193	288	Blocking
2 - Beveled Plate - SPF	3,50"	3,50"	1,50"	259	493	753	None
3 - Beveled Plate - SPF	3,50"	3,50"	1,50"	81	166	247	Blocking

- Blocking Panels are assumed to carry no loads applied directly above them and the full load is applied to the member being designed.

Lateral Bracing	Bracing Intervals	Comments
Top Edge (Lu)	13' o/c	
Bottom Edge (Lu)	7' 6" o/c	

•Maximum allowable bracing intervals based on applied load.

Vertical Load	Location (Side)	Spacing	Dead (0,90)	Roof Live (non-snow: 1,25)	Comments
1 - Uniform (PSF)	0 to 31'	16"	10,0	20,0	Default Load

**Weyerhaeuser Notes**

Weyerhaeuser warrants that the sizing of its products will be in accordance with Weyerhaeuser product design criteria and published design values. Weyerhaeuser expressly disclaims any other warranties related to the software. Use of this software is not intended to circumvent the need for a design professional as determined by the authority having jurisdiction. The designer of record, builder or framer is responsible to assure that this calculation is compatible with the overall project. Accessories (Rim Board, Blocking Panels and Squash Blocks) are not designed by this software. Products manufactured at Weyerhaeuser facilities are third-party certified to sustainable forestry standards. Weyerhaeuser Engineered Lumber Products have been evaluated by ICC-ES under evaluation reports ESR-1153 and ESR-1387 and/or tested in accordance with applicable ASTM standards. For current code evaluation reports, Weyerhaeuser product literature and installation details refer to [www.weyerhaeuser.com/woodproducts/document-library](http://www.weyerhaeuser.com/woodproducts/document-library).

The product application, input design loads, dimensions and support information have been provided by ForteWEB Software Operator

NUMBER	DATE	REVISION TABLE	REVISION BY	DESCRIPTION

RELEASED FOR CONSTRUCTION

NEW CONSTRUCTION  
 103 14th Street  
 Cumming, GA 30043



DATE:  
6/13/2023

SCALE:

SHEET:

S1.12

Proposed Roof Framing Plan, Rafter "B"  
**1 piece(s) 2 x 6 SPF No.1/No.2 @ 16" OC**

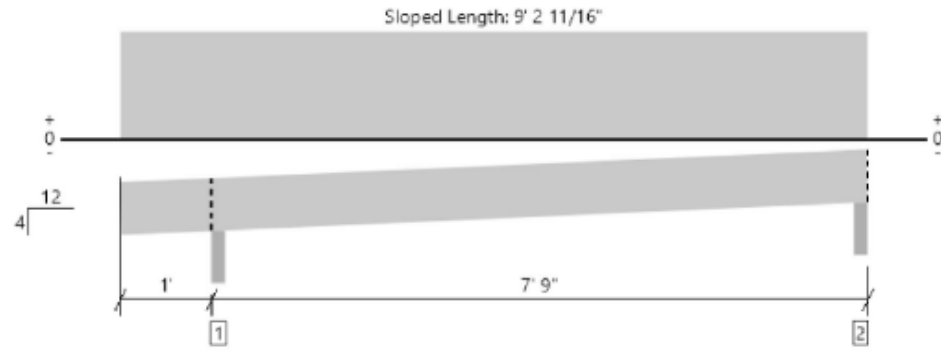

All locations are measured from the outside face of left support (or left cantilever end). All dimensions are horizontal.

Member Length : 9' 4 1/2"

Design Results	Actual @ Location	Allowed	Result	LDF	Load: Combination (Pattern)
Member Reaction (lbs)	201 @ 1' 1 3/4"	2352 (3,50")	Passed (9%)	-	1.0 D + 1.0 Lr (All Spans)
Shear (lbs)	131 @ 1' 8 11/16"	928	Passed (14%)	1.25	1.0 D + 1.0 Lr (All Spans)
Moment (Ft-lbs)	270 @ 4' 10 13/16"	1030	Passed (26%)	1.25	1.0 D + 1.0 Lr (All Spans)
Live Load Defl. (in)	0,067 @ 4' 10 5/16"	0,390	Passed (L/999+)	-	1.0 D + 1.0 Lr (All Spans)
Total Load Defl. (in)	0,101 @ 4' 10 3/8"	0,520	Passed (L/930)	-	1.0 D + 1.0 Lr (All Spans)

System : Roof  
 Member Type : Joist  
 Building Use : Residential  
 Building Code : IBC 2018  
 Design Methodology : ASD  
 Member Pitch : 4/12

- Deflection criteria: LL (L/240) and TL (L/180).
- Overhang deflection criteria: LL (2L/240) and TL (2L/180).
- Allowed moment does not reflect the adjustment for the beam stability factor.
- A 15% increase in the moment capacity has been added to account for repetitive member usage.
- Applicable calculations are based on NDS.

Supports	Bearing Length			Loads to Supports (lbs)			Accessories
	Total	Available	Required	Dead	Roof Live	Factored	
1 - Beveled Plate - SPF	3,50"	3,50"	1,50"	69	132	201	Blocking
2 - Beveled Plate - SPF	3,50"	3,50"	1,50"	54	103	157	Blocking

• Blocking Panels are assumed to carry no loads applied directly above them and the full load is applied to the member being designed.

Lateral Bracing	Bracing Intervals	Comments
Top Edge (Lu)	9' 3" o/c	
Bottom Edge (Lu)	9' 3" o/c	

• Maximum allowable bracing intervals based on applied load.

Vertical Load	Location (Side)	Spacing	Dead (0,90)	Roof Live (non-snow: 1,25)	Comments
1 - Uniform (PSF)	0 to 8' 9"	16"	10,0	20,0	Default Load

**Weyerhaeuser Notes**  
 Weyerhaeuser warrants that the sizing of its products will be in accordance with Weyerhaeuser product design criteria and published design values. Weyerhaeuser expressly disclaims any other warranties related to the software. Use of this software is not intended to circumvent the need for a design professional as determined by the authority having jurisdiction. The designer of record, builder or framer is responsible to assure that this calculation is compatible with the overall project. Accessories (Rim Board, Blocking Panels and Squash Blocks) are not designed by this software. Products manufactured at Weyerhaeuser facilities are third-party certified to sustainable forestry standards. Weyerhaeuser Engineered Lumber Products have been evaluated by ICC-ES under evaluation reports ESR-1153 and ESR-1387 and/or tested in accordance with applicable ASTM standards. For current code evaluation reports, Weyerhaeuser product literature and installation details refer to [www.weyerhaeuser.com/woodproducts/document-library](http://www.weyerhaeuser.com/woodproducts/document-library).  
 The product application, input design loads, dimensions and support information have been provided by ForteWEB Software Operator

REVISION TABLE	NUMBER	DATE	REVISED BY	DESCRIPTION

RELEASED FOR CONSTRUCTION

NEW CONSTRUCTION  
 103 14th Street  
 Cumming, GA 30043



DATE:  
6/13/2023

SCALE:

SHEET:  
S1.13