

**Revista Mexicana de
Astronomía y Astrofísica**

Revista Mexicana de Astronomía y Astrofísica

ISSN: 0185-1101

rmaa@astroscu.unam.mx

Instituto de Astronomía

México

Garzón, F.; Fuentes, F. J.; Manescau, A.; Díaz, J. J.; Patrón, J.; Pelló, R.; López, J.C.; Pérez, J.;
Fragoso, A. B.; Gago, F.; Beigbeder, F.; Sánchez, V.; Correa, S.; Villegas, A.

EMIR: a Near-Infrared Multiobject Spectrograph for the GTC

Revista Mexicana de Astronomía y Astrofísica, vol. 16, febrero, 2003, pp. 23-31

Instituto de Astronomía

Distrito Federal, México

Available in: <http://www.redalyc.org/articulo.oa?id=57116007>

- How to cite
- Complete issue
- More information about this article
- Journal's homepage in redalyc.org

redalyc.org

Scientific Information System

Network of Scientific Journals from Latin America, the Caribbean, Spain and Portugal

Non-profit academic project, developed under the open access initiative

EMIR: A NEAR-INFRARED MULTIOBJECT SPECTROGRAPH FOR THE GTC

F. Garzón,^{1,2} F. J. Fuentes,¹ A. Manescau,¹ J. J. Díaz,¹ J. Patrón,¹ R. Pelló,³
J. C. López,¹ J. Pérez,¹ A. B. Fragoso,¹ F. Gago,¹ F. Beigbeder,³ V. Sánchez,¹
S. Correa¹ and A. Villegas,¹

RESUMEN

Presentamos las características generales de EMIR, el espectrógrafo multiobjeto infrarrojo para GTC. EMIR se encuentra actualmente en mitad de su fase de diseño preliminar, y está concebido para ser uno de los primeros instrumentos de uso común del GTC, el telescopio de 10 metros que se construye actualmente en el Observatorio del Roque de los Muchachos, en Canarias (España). La construcción de EMIR se lleva a cabo por un Consorcio de institutos españoles, franceses y británicos, liderados por el IAC. El diseño de EMIR permitirá el acceso a uno de los objetivos centrales de los telescopios de clase 10 m, ofreciendo a los usuarios la obtención de un gran número de espectros de fuentes débiles con gran eficacia en el uso del tiempo disponible. EMIR está concebido para ser usado principalmente como multiobjeto en la banda K , pero ofrece un amplio rango de modos de observación adicionales, que incluyen imagen y espectroscopía, de rendija larga y multirendija, en el rango espectral de 0.9 a 2.5 μm . Revisamos el estado actual de desarrollo, las prestaciones previstas y se describe el plan de ejecución. Este proyecto está financiado por GRANTECAN y el Plan Nacional de Astronomía y Astrofísica.

ABSTRACT

In this contribution, we review the overall features of EMIR, the NIR multiobject spectrograph of the GTC. EMIR is at present in the middle of its PD phase and will be one of the first common user instruments for the GTC, the 10 meter telescope under construction by GRANTECAN at the Roque de los Muchachos Observatory (Canary Islands, Spain). EMIR is being built by a Consortium of Spanish, French, and British institutes led by the IAC. EMIR is designed to realize one of the central goals of 10 m class telescopes, that of allowing observers to obtain spectra for large numbers of faint sources in a time-efficient manner. EMIR is primarily designed to be operated as a MOS in the K band but offers a wide range of observing modes, including imaging and spectroscopy, both long slit and multiobject, in the wavelength range 0.9 to 2.5 μm . The present status of development of EMIR, its expected performance, and the project schedule are described and discussed. This project is funded by GRANTECAN and the *Plan Nacional de Astronomía y Astrofísica* (National Plan for Astronomy and Astrophysics, Spain).

Key Words: **INSTRUMENTATION: DETECTORS — INSTRUMENTATION: SPECTROGRAPHS — TECHNIQUES: SPECTROSCOPIC**

1. INSTRUMENT DESCRIPTION

The new generation of 10 meter class optical and near-infrared telescopes currently under construction by European and American institutions, or in early phases of their lives, penetrating ever deeper into the Universe, hold the promise of providing, for the first time, a direct view of the processes that have shaped the formation stars, galaxies, and the Universe itself. Also, they will provide, again for the first time, the capability of detecting and isolating

extragalactic stars and star forming regions with unprecedented sensitivity and resolving power, both spatial and spectral. A collective instrumentation effort is under way to allow these new infrastructures to be used to their full potential. The scientific capabilities of the new telescopes are thought to be enormous not only because of their larger photon-collecting area but above all because of the new instruments, which, through major technological advances, are expected to be orders of magnitude more efficient than their present-day counterparts.

The Roque de los Muchachos Observatory, operated by the Instituto de Astrofísica de Canarias (IAC) on the island of La Palma, will be the site of

¹Instituto de Astrofísica de Canarias, Tenerife, Spain

²Departamento de Astrofísica. Universidad de La Laguna, Tenerife, Spain

³Laboratoire d'Astrophysique Observatoire de Midi Pyrénées, France

the 10 meter Gran Telescopio Canarias (GTC) due for first light in 2003. The GTC will be the largest-aperture European telescope in the northern hemisphere. Since mid-1998, a partnership of Spanish, French and British research institutions have been working on the design and construction of EMIR, an advanced NIR multiobject spectrograph for the GTC, which will be described in this contribution.

EMIR (*Espectrógrafo Multiobjeto Infrarrojo*) is a common-user, wide field, near-infrared (NIR) camera-spectrograph operating at near-infrared wavelengths 0.9–2.5 μm , using cryogenic multislit masks. Its specifications are listed in Table 1. EMIR will provide the GTC with imaging, long-slit and multiobject spectroscopic capabilities. The EMIR consortium, led by the IAC, includes world-class experts with a strong track record in the development of innovative telescopes and IR instruments for large telescopes. It is formed by the IAC and Universidad Complutense de Madrid (UCM) (Spain), the Laboratoire d’Astrophysique des Midi Pyrénées (LAOMP) (France), and the University of Durham (UK). In March 1999, GRANTECAN selected EMIR as one of GTC’s first-generation science instruments (EMIR changed to a second-generation instrument in early 2000. After going through a major simplification phase, aimed at ensuring the feasibility and availability of the instrument at the GTC, EMIR is now in the middle of its preliminary design (PD) phase, which is due in 2003 February. This phase is being funded by GRANTECAN and the *Plan Nacional de Astronomía y Astrofísica*.

EMIR will provide the GTC user community with key new observing capabilities. It is expected that it will be the first fully cryogenic multiobject spectrograph (MOS) on a 10 m class telescope, hence it will be able to observe in the *K* band (2.2 μm) without the disadvantage of the high instrumental background common to other conceptually similar instruments. Similar NIR MOSs, already existing or planned for other telescopes, are not cooled and reach only to 1.8 μm . Extending wavelength coverage to 2.2 μm is the natural next step in MOS design. EMIR will open up, for the first time, the study of the nature of galaxies at redshifts beyond $z = 2$ with unprecedented depth and field of view. At these redshifts, the well-studied visible rest-frame of galaxies, in particular the strong $\text{H}\alpha$ line, is shifted to the *K* band (see Figure 1), allowing key diagnostics of the star formation history of the Universe to be obtained. EMIR will allow us to bridge the gap between extensive studies at lower redshifts carried out in the nineties on 4 m class telescopes and those

above $z = 6$ planned for the near future using the far infrared and millimeter wavelengths. EMIR will also provide a link between current spectroscopic capabilities and those that will become available when the *Next Generation Space Telescope (NGST)* becomes operational towards the end of this decade.

EMIR’s design was largely determined by the requirements of the main scientific driver, the study of faint, distant galaxies (the COSMOS project, see Balcells, this volume, p. 71; Guzmán, this volume, p. 214, and references therein). Being a common-user instrument, however, EMIR has been designed to meet many of the broader requirements of the astronomical community. It is therefore a versatile instrument that will accomplish a wide variety of scientific projects in extragalactic, stellar, and Solar System astronomy.

The construction of EMIR pushes large-telescope instrumentation to new limits. The 10 m aperture of the GTC translates into a physically large focal surface. Matching the images given by the telescope to the small size of current detectors requires large optics with fast cameras. Large, heavy optics need advanced mechanical design and modeling to bring flexure to within acceptable levels. To work in the region beyond 1.8 μm , EMIR’s optical system and mechanical structure will be cooled to cryogenic temperatures. Temperature stability and cycle-time requirements pose stringent demands on the design and performance of the instrument’s cryogenic system. A key module of EMIR is a cryogenic mask unit (CMU) to allow several different configurations of multi-slit masks being available every night, suitable for the GTC’s intended queue observing, without warming the spectrograph. All the aforementioned aspects need development effort, as the technology is either not available or is not scalable from existing solutions. Finally, we are seeking the development of a documented, robust processing pipeline as an integral part of the instrument and are including a software effort in the developments commensurate with the requirements for EMIR’s successful operation.

In the following sections, we shall briefly review the different technical aspects of the EMIR design effort. It is worth emphasizing again that EMIR is a science-driven instrumental project, its top level design requirements being taken directly from the main goals of the COSMOS project; but, at the same time, it is conceived as a powerful and flexible common-user instrument which will open new windows to the community it serves. It is also planned to extend the present-day EMIR scientific team, mostly focused on

TABLE 1
TOP LEVEL INSTRUMENT SPECIFICATIONS OF EMIR

Wavelength range	0.9–2.5 μm
Optimization	1.0–2.5 μm
Observing modes	Multiobject spectroscopy Wide-field Imaging
Top priority mode	K band multiobject spectroscopy
Spectral resolution	4000 for 0.6'' (3 pixel) wide apertures 6000 for 0.4'' (2 pixel) wide apertures
Spectral coverage	One observing window (Z , J , H or K) per single exposure
Array format	2048 \times 2048 HgCdTe (Rockwell-Hawaii2)
Scale at detector	0.2 arcsec/pixel
OH suppression	In software
Image quality	$\theta_{80} < 0.6$ arcsec
Multiobject mode	
Slit area	6' \times 4', minimum of 20 slitlets ($\approx 0.6'' \times 8''$)
Sensitivity	$K > 20.2$, $t = 4$ h, $S/N = 5$ per FWHM (continuum) $F > 5 \times 10 \text{ erg s}^{-1} \text{ cm}^{-1} \text{ \AA}^{-1}$, $t = 4$ h, $S/N = 6$ per FWHM (line)
Imaging mode	
FOV	6' \times 6'
Sensitivity	$K > 23.5$, $t = 4$ h, $S/N = 5$, in 0''.65 aperture

Science with the GTC 10-m Telescope (Granada, España, 5-8 febrero 2002)
Editors: José Miguel Rodríguez Espinosa, Francisco Garzón López & Verónica Melo Marfín

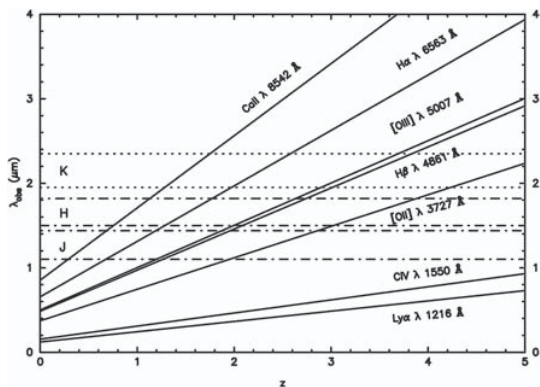

Fig. 1. Observed wavelengths of the most representative emission and absorption lines in normal galaxy spectra at various redshifts.

COSMOS, at the end of the PD phase, thereby permitting the coverage and early preparation of a wider list of scientific topics.

2. EMIR AND THE COSMOS PROJECT

The instrumental concept of EMIR is closely related with the principal objectives of the COSMOS project (Balcells, this volume, p. 71; Guzmán, this volume, p. 214). In summary, COSMOS is intended

to compile a rather complete census of the population of the compact blue luminous emission line galaxies at redshifts in the range 1–2, an epoch of great enhancement of the stellar formation rate in the history of the Universe. To this end, a large-aperture telescope, e.g., the GTC, is needed because of the intrinsic faintness of the sources.

In addition, a spectrograph working in the NIR is mandatory for the project since at those redshifts the diagnostic lines used to delineate star formation, e.g., $H\alpha$, lie in the NIR (see Figure 1). Finally, a multiobject capability is needed because of the high number density of objects to be measured and the need for an efficient way of doing this.

3. OPTICAL LAYOUT

The optical concept of EMIR has been studied using many approaches in order to get a good balance among the performance of the instrument, the technical risks, and the overall price. EMIR's requirements make the optical concept extremely challenging, and the design approaches have tried to minimize the trade-off between requirements and technical solutions.

The main parameter driving the design is the size of the required FOV in both imaging (6' \times 6') and spectroscopic (at least 6' \times 3') modes. Requirements

such spectral resolution, operating temperature, and material availability are also important and have special role in the final design.

EMIR's current optical design uses gratings as the dispersive element. This option appears to be the most feasible approach, with a strong caveat concerning the unavailability of such gratings on the market. Technical developments to procure large gratings with high refractive index materials are needed, but the EMIR project is by no means unique in this respect, and we currently envisage some work in this area with our industrial partners. The grating option has been chosen because a number of advantages:

- A centrally symmetric system could be designed so that aberration compensation would be easier than in an off-axis system.
- The use of gratings simplifies the camera design because the camera itself is placed nearer to the cold stop.
- The analysis of performance is much simpler because of its symmetry.
- It might be easier to test independent subsystems (the collimator and/or camera).

A primary feature in the optical design of an infrared camera is its cold aperture stop for reducing the background noise. The GTC entrance pupil or aperture stop is the secondary mirror, as in any infrared telescope. The size of the cold stop is defined principally by the required spectral resolution ($R > 4000$). We chose a collimated beam of 100 mm diameter to achieve a resolution of 4250 with a 40° ZnSe ($n > 2.45$) grating, with a slit width of 0.6 arcsec (the fabrication of this grating is still under evaluation with manufacturers).

A refractive collimator is designed to form an image of the secondary mirror (cold stop) 250 mm beyond the last element and produces a collimated beam into which the filters and gratings are inserted. As mentioned, the nominal diameter of the cold stop is 100 mm.

The design has been carried out in stages, starting with the collimator, which must provide a parallel beam and a "sharp" pupil image of 100 mm diameter. The design of this subsystem was driven by the need to get a good full-field polychromatic pupil image, and little attention was paid to the color correction in the final image. The implementation of the camera was carried out once its performance as stand-alone system exceeded (in terms of polychromatic spot size) the final EMIR requirement over a

wide field and with a rather larger stop distance than the final one in the instrument.

Optimization was performed taking into account both WFIM and MSSM, weighting the spectroscopic mode with higher values. The final analysis of the system shows some ghost problems, which were controlled in the final tuning of the instrument. The five-lens refractive camera (two aspheric surfaces on CaF₂ and ZnSe) is located 135 mm from the cold stop and produces an $f/1.91$ image on the detector, the final image scale being 0.2 arcsec/pixel. Refocusing by movement of the detector along the optical axis is necessary for tuning the image quality for each photometric band in WFIM and for each grating in MSSM. The developed system has a centered layout, as shown unfolded in Figure 2 and folded in Figure 3, using the current packaging. The optical performance is summarized in Table 2. The achieved figures met the requirements specified by the scientific team.

4. MECHANICAL CONCEPT

The present version of EMIR is a simplified version of the original concept, as mentioned in §1, the main difference being the limitation in the number of multislit masks available to observers during the observing night. This will allow the masks to be mounted in a wheel, whereas plans for the final instrument include the exploration of a cold reconfigurable slit mechanism. Care is being taken to maintain the interface compatibility of EMIR with both mechanisms.

EMIR will be attached to the mechanical rotator of the Nasmyth-B focus. The mechanical layout of the instrument has been defined from the optical design (see §3) taking into account the Nasmyth space envelope. Two flats have been added to bend the beam and a cold bench has been optimized to fulfill the image stability error budget. A mechanical concept has been developed for each subsystem, and a first draft of the specifications has been obtained to feed the preliminary design. Trade-off studies are under development to homogenize as much as possible the technical solutions adopted for the cold mechanisms.

EMIR consists of several mechanical subsystems which must be mounted in a limited cold space. The geometrical envelope and weight of the whole instrument are limited by the telescope interface constraints to $3.25 \text{ m} \times 3 \text{ m} \times 3 \text{ m}$ and 2400 kg. The instrument subsystems are four lens barrels, one slit wheel (plus an optional decenter wheel) which forms the cold mask unit (CMU), two filter wheels, one

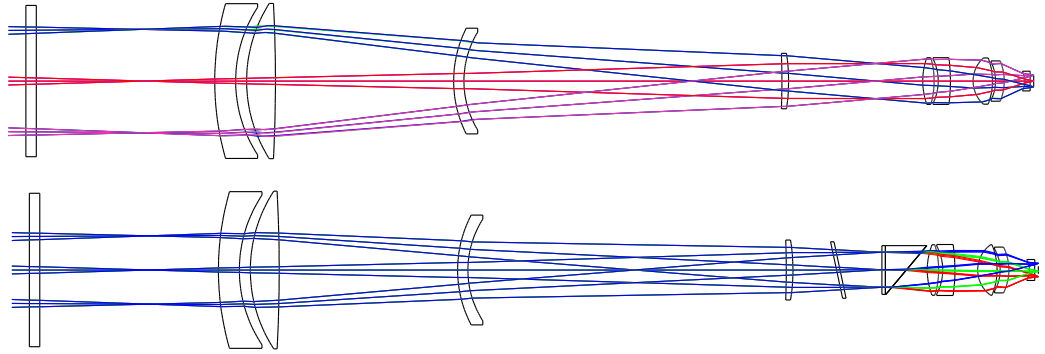

Fig. 2. Current EMIR optical design (unfolded).

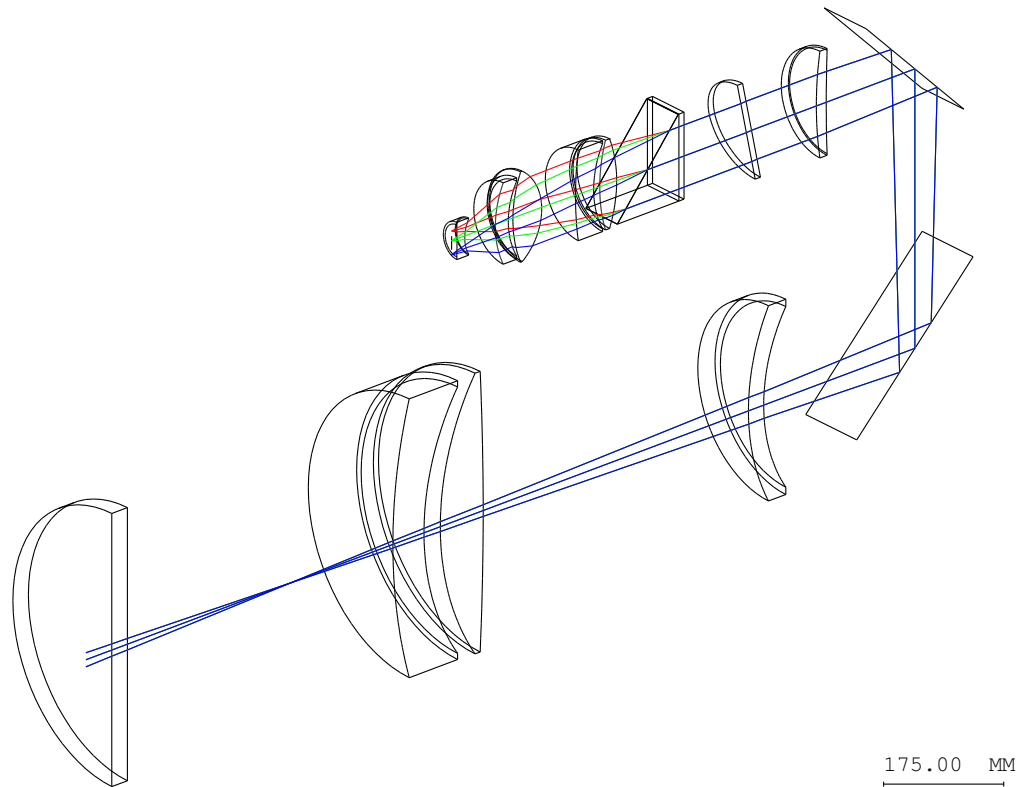

Fig. 3. Current EMIR optical design (folded).

grism wheel, a detector board mounted on a focusing mechanism and a periscope that encloses the two flats to fold the optical beam. All the subsystems must operate at LN_2 temperature inside a cryostat that will be attached mechanically to the Nasmyth rotator. A 3D cold bench, as axisymmetrical as pos-

sible, has been designed to provide support for the cold elements and to avoid imbalance of forces when the instrument rotates. This cold bench is shown in Figure 4. This structure supports the spectrograph's cold subassemblies, except for the CMU. A central ring, placed on a balanced surface, is used to attach

TABLE 2
MAIN PERFORMANCE CHARACTERISTICS OF THE
CURRENT EMIR OPTICAL DESIGN

Field of view	WFIM: $6' \times 6'$
	MSSM: $6' \times 4'$
Image scale	0.2 arcsec/pixel
Spectral resolution	<i>K</i> band: 3500
	<i>H</i> band: 4250
	<i>J</i> band: 4250
Averaged image quality (80%EED)	WFIM: 0.0254 ± 0.0021 mm
	MSSM: 0.0303 ± 0.0019 mm
Distortion (WFIM)	< 1.16%
Transmission (WFIM)	67%
Refocus range	-0.051/+0.0141 mm

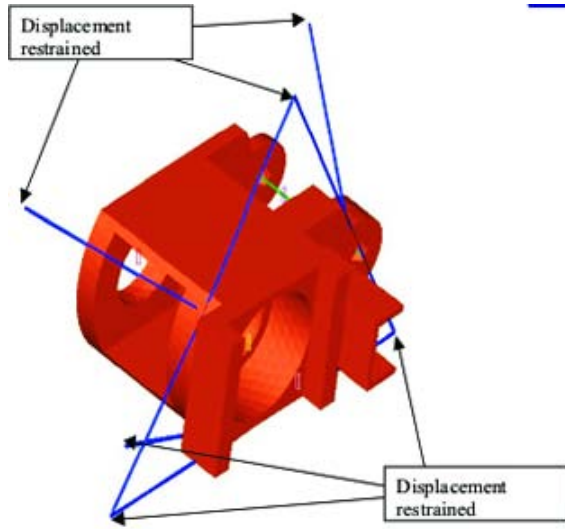

Fig. 4. Principal mechanical structure of the instrument (cold bench).

the optical bench to the cryostat by means of support trusses arranged in isostatically. These support trusses will be conformed by an insulating thermal material and are integrated in the cold structure sub-system.

The mechanical design is driven by the size of the optical components (slit masks have a physical size of $350 \text{ mm} \times 350 \text{ mm}$, whereas the first doublet lenses of the collimator have a diameter of 470 mm), the resulting size of the wheel mounting optical components (all the wheels will have about 1 m diameter), the stringent top level requirements (image stability must be better than $5 \mu\text{m}$ in spectroscopic mode

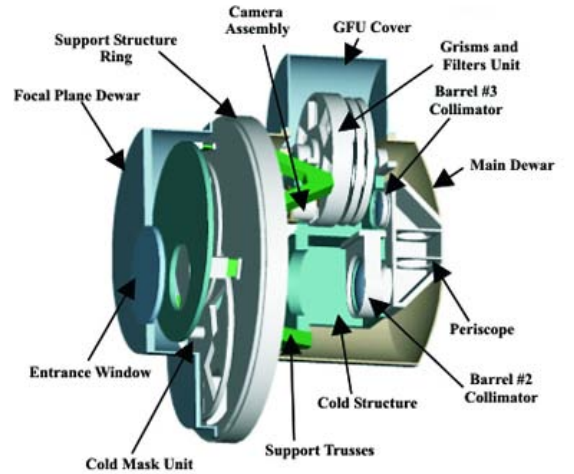

Fig. 5. EMIR mechanical layout, with the wheel for the slit masks.

when the instrument rotates through 180°), and the interface constraints. Both filter wheels will have eight positions for filters (with a maximum of 14 filters), whereas the grism wheel will have up to six positions, so that a maximum of five grisms will be used.

The global structural configuration, shown in Figure 5, is based on the concept of two vacuum/cooling spaces, the first containing the main instrument (including the optics, the filter and grism wheels, and the detector) and the second containing the multislit masks. Both spaces have a common flange, the slit mask cryostat being mounted on the front surface of the main cryostat, and are cooled independently.

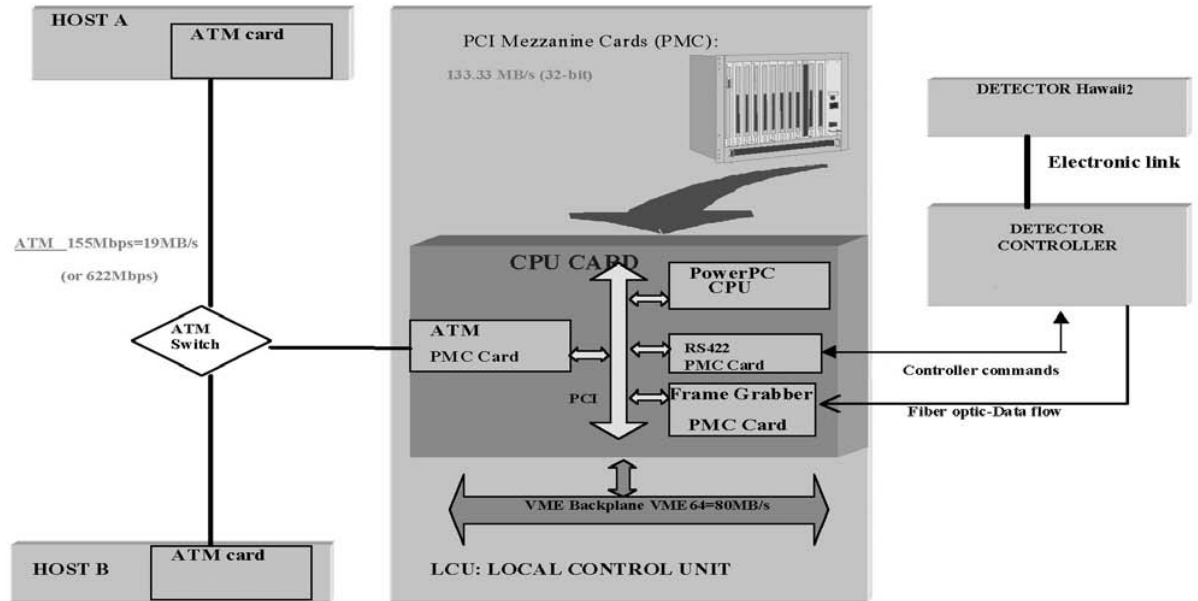

Fig. 6. Schematic view of the hardware design of the DAS.

The slit mask mechanism must be capable of thermal cycling between the LN_2 working temperature to room temperature and again to LN_2 conditions on a daily basis without any variation in the working conditions inside the main cryostat to allow the observing multislit masks to be changed from night to night. The CMU allows EMIR to do spectroscopy by inserting a slit mask in the focal plane. It consists of a mask-wheel drive system and its cold structure, to be integrated directly in the secondary dewar, which will be frontally assembled to the main one. In spectroscopic mode, a cold mask wheel will select and insert/remove spectroscopic masks into/from the telescope focal plane. A number of fixed-width long-slit masks will be available in addition to user-customized masks for multi-object spectroscopy.

5. CONTROL SYSTEM

The EMIR control system is being developed by a multi-institutional group formed by scientist and engineers from the IAC, UCM and LAOMP, under the coordination of the IAC. The system follows strictly the prescription of GRANTECAN for the development of instrument control systems, in view of the subsequent integration into the global GTC control system. There are four main aspects in the control system that have been considered as an integral part of the instruments from the beginning:

- EMIR Coordinated Operations (ECOs), which include the control of the instrument global configuration relating to observations and calibrations. These might have to interact with the GTC control system. It is being built in cooperation by IAC and LAOMP.
- The EMIR Data Acquisition System (DAS), which drives the detector readout modes and controls the flow of data. It is being developed by the IAC. Its present design is shown in Figure 6.
- The EMIR Observing Programme Management Subsystem (EOPMS, formerly EOPMT), the master program that monitors EMIR's performance and will ensure the adequate use of the EMIR instrument by regular astronomers. Its design is being undertaken by LAOMP. See Figure 7 for a sketch of the EOPMT.
- The Data Reduction Pipeline (DRP), which includes specific filters and reduction packages for each observing mode. It is under the responsibility of the UCM.

6. MANAGEMENT AND SCHEDULE TO PDR: PLAN TO COMPLETION

As mentioned in §1, EMIR is now going through its PD phase. The work is proceeding as expected,

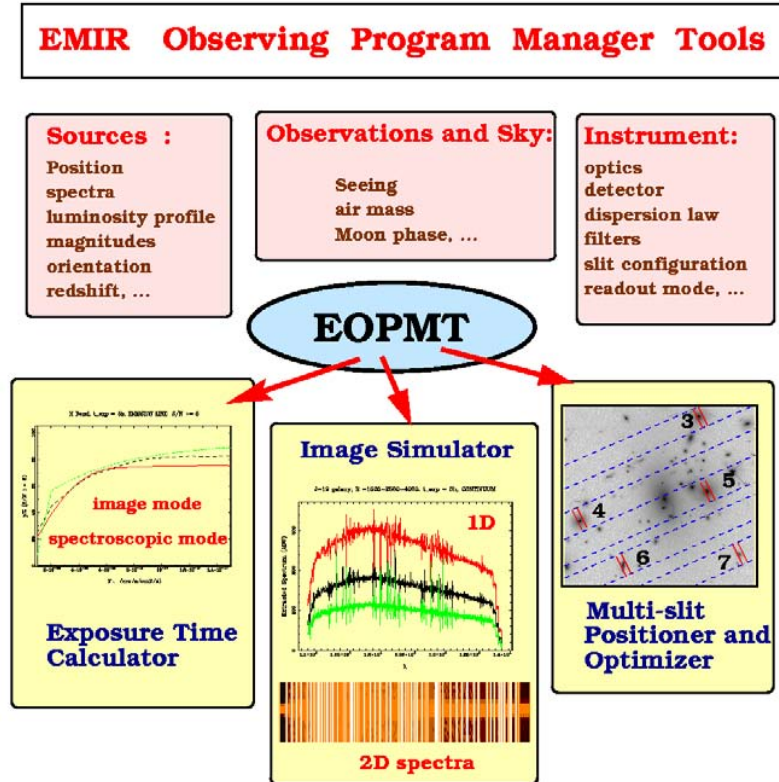

Fig. 7. Schematic view of the EOPMS.

the major challenges being the procurement of the large size grism(s) needed for the light dispersion and the CMU. With respect to the grisms, and after being in touch with just about all of the existing grism suppliers (and receiving very few positive replies), we are now in advanced negotiations with a selected firm that has performed a similar task in the past. We expect to be able to launch a development programme before summer aimed at proving the feasibility of that component. In view of the high risk of not having this critical component on time, we have evaluated the performance of the optical design using an existing lower resolving power grism element. The results are very satisfactory from the point of view of general image quality, so this approach may now be considered as a fall-back solution for EMIR until such time as the optimum grism(s) is (are) available.

As far as the CMU is concerned, the wheel approach described in §4 is considered to be the baseline until PDR. This design effort is being performed by the University of Durham under contract and in

cooperation with the IAC. The top design driver is to be able to accommodate at least three slit-masks (300 mm × 300 mm each) and still keep the full cycling time below 12 hours. More innovative and better in performances and versatility, a second approach based on linearly shifted metallic bars, which form the slitlets, is now being explored. We plan also to set up a feasibility study that must revise the use of existing technologies in this field. The contractor for this work has been already selected.

With all the above in mind, we are now facing a schedule to PDR that contemplates three major milestones:

- An internal review of the optical design, which will take place in early summer.
- A Mid-Term Review (organized by GRANTECAN) by 2002 October/November.
- The PDR by 2003 February.

Last but not least, we currently envisage the

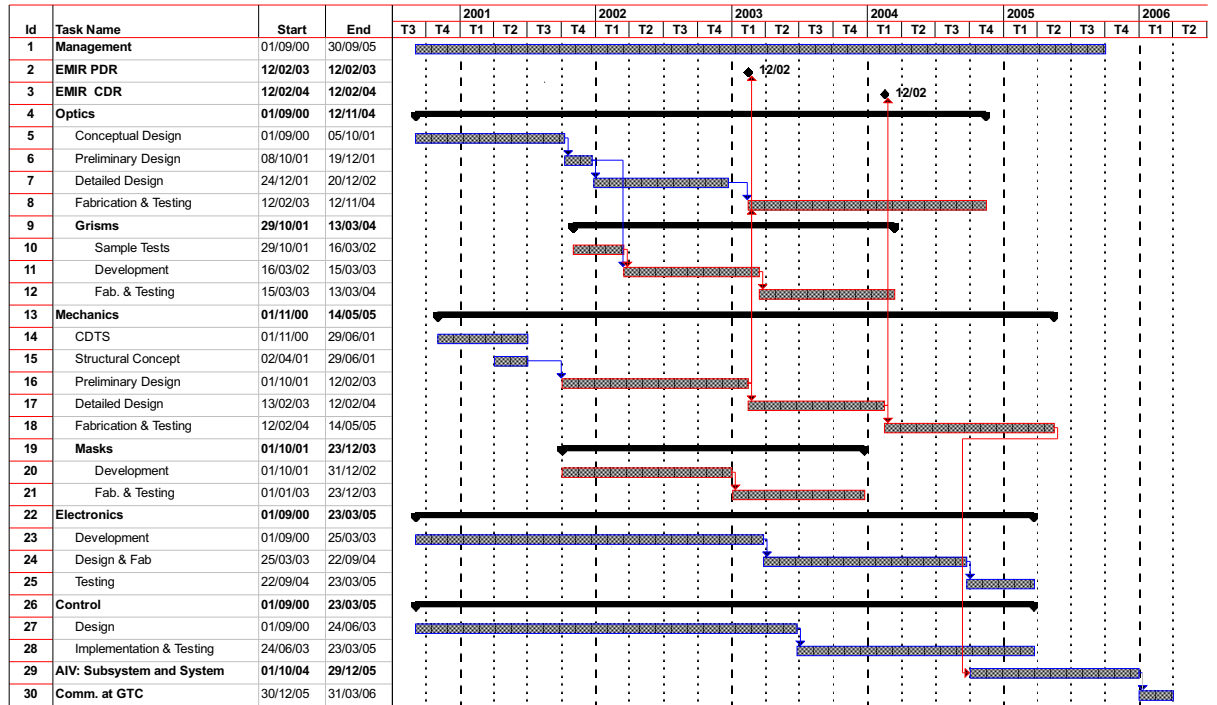

Fig. 8. General schedule plan of EMIR to completion.

management of the final schedule to completion. With the project's still remaining many uncertainties, our best approach until now is presented in Figure 5, which prognosticates EMIR starting routine scientific operations on the GTC at the beginning of 2006.

The design effort of EMIR during this Preliminary Design Phase is largely supported by the *Plan Nacional de Astronomía y Astrofísica*, throughout the project AYA-2001-1656, and by the GRANTE-CAN Project Office, via a dedicated contract.

- F. Garzón, F. J. Fuentes, A. Manescau, J. J. Díaz, J. Patrón, J. C. López, J. Pérez, A. B. Fragoso, F. Gago, V. Sánchez, S. Correa, and A. Villegas: Instituto de Astrofísica de Canarias, E-38205 La Laguna, Tenerife, Spain (fgl,fjf,amh,jdg,jpr,jlopez,jperez,afragoso,fgago,vsr,scorrea, alejovil@ll.iac.es)
- R. Pelló and F. Beigbeder: Laboratoire d'Astrophysique Observatoire de Midi Pyrénées, 14 avenue Edouard Belin, F-31400 Toulouse, France (rosier,francis.beigbeder@obs-mip.fr)